

SERVICE MANUAL

**AC Power Source/Analyzer
HP Models 6814B and 6834B**

**Regulatory Test Solution (RTS) - formerly called
the Harmonic/Flicker Test System (HFTS)
HP Model 6843A**

HP Part No 5962-0891

For instruments with Serial Numbers:

**HP Model 6814B: 3601A-00101 through 00272
US36010273 and up**

**HP Model 6834B: 3601A-00101 through 00403
US36010404 and up**

**HP Model 6843A: 3531A-00101 through 00256
US35310257 and up**

CERTIFICATION

Hewlett-Packard Company certifies that this product met its published specifications at time of shipment from the factory. Hewlett-Packard further certifies that its calibration measurements are traceable to the United States National Bureau of Standards, to the extent allowed by the Bureau's calibration facility, and to the calibration facilities of other International Standards Organization members.

WARRANTY

This Hewlett-Packard hardware product is warranted against defects in material and workmanship for a period of three years from date of delivery. HP software and firmware products, which are designated by HP for use with a hardware product and when properly installed on that hardware product, are warranted not to fail to execute their programming instructions due to defects in material and workmanship for a period of 90 days from date of delivery. During the warranty period Hewlett-Packard Company will, at its option, either repair or replace products which prove to be defective. HP does not warrant that the operation of the software, firmware, or hardware shall be uninterrupted or error free.

For warranty service, with the exception of warranty options, this product must be returned to a service facility designated by HP. Customer shall prepay shipping charges by (and shall pay all duty and taxes) for products returned to HP for warranty service. Except for products returned to Customer from another country, HP shall pay for return of products to Customer.

Warranty services outside the country of initial purchase are included in HP's product price, only if Customer pays HP international prices (defined as destination local currency price, or U.S. or Geneva Export price).

If HP is unable, within a reasonable time to repair or replace any product to condition as warranted, the Customer shall be entitled to a refund of the purchase price upon return of the product to HP.

LIMITATION OF WARRANTY

The foregoing warranty shall not apply to defects resulting from improper or inadequate maintenance by the Customer, Customer-supplied software or interfacing, unauthorized modification or misuse, operation outside of the environmental specifications for the product, or improper site preparation and maintenance. **NO OTHER WARRANTY IS EXPRESSED OR IMPLIED. HP SPECIFICALLY DISCLAIMS THE IMPLIED WARRANTIES OF MERCHANTABILITY AND FITNESS FOR A PARTICULAR PURPOSE.**

EXCLUSIVE REMEDIES

THE REMEDIES PROVIDED HEREIN ARE THE CUSTOMER'S SOLE AND EXCLUSIVE REMEDIES. HP SHALL NOT BE LIABLE FOR ANY DIRECT, INDIRECT, SPECIAL, INCIDENTAL, OR CONSEQUENTIAL DAMAGES, WHETHER BASED ON CONTRACT, TORT, OR ANY OTHER LEGAL THEORY.

ASSISTANCE

The above statements apply only to the standard product warranty. Warranty options, extended support contracts, product maintenance agreements and customer assistance agreements are also available. Contact your nearest Hewlett-Packard Sales and Service office for further information on HP's full line of Support Programs.

SAFETY CONSIDERATIONS

GENERAL. This is a Safety Class 1 instrument (provided with terminal for connection to protective earth ground).

OPERATION. BEFORE APPLYING POWER verify that the product is set to match the available line voltage, the correct line fuse is installed, and all safety precautions (see following warnings) are taken. In addition, note the instrument's external markings described under "Safety Symbols".

WARNING.

- Servicing instructions are for use by service-trained personnel. To avoid dangerous electrical shock, do not perform any servicing unless you are qualified to do so.
- BEFORE SWITCHING ON THE INSTRUMENT, the protective earth terminal of the instrument must be connected to the protective conductor of the (mains) power cord. The mains plug shall be inserted only in an outlet socket that is provided with a protective earth contact. This protective action must not be negated by the use of an extension cord (power cable) that is without a protective conductor (grounding). Grounding one conductor of a two-conductor outlet is not sufficient protection.
- If this instrument is to be energized via an auto-transformer (for voltage change), make sure the common terminal is connected to the earth terminal of the power source.
- Any interruption of the protective (grounding) conductor (inside or outside the instrument), or disconnecting of the protective earth terminal will cause a potential shock hazard that could result in personal injury.
- Whenever it is likely that the protective earth connection has been impaired, this instrument must be made inoperative and be secured against any unintended operation.
- Only fuses with the required rated current, voltage, and specified type (normal blow, time delay, etc.) should be used. Do not use repaired fuses or short-circuited fuseholders. To do so could cause a shock or fire hazard.
- Do not operate this instrument in the presence of flammable gases or fumes.
- Do not install substitute parts or perform any unauthorized modification to this instrument.
- Some procedures described in this manual are performed with power supplied to the instrument while its protective covers are removed. If contacted, the energy available at many points may result in personal injury.
- Any adjustment, maintenance, and repair of this instrument while it is opened and under voltage should be avoided as much as possible. When this is unavoidable, such adjustment, maintenance, and repair should be carried out only by a skilled person who is aware of the hazard involved.
- Capacitors inside this instrument may hold a hazardous electrical charge even if the instrument has been disconnected from its power source.

SAFETY SYMBOLS.



This symbol indicates that the instrument will be marked with this symbol when it is necessary for you to refer to the instruction manual in order to protect against damage to the instrument.



This sign indicates hazardous voltages.

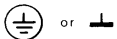

This sign indicates an earth terminal (sometimes used in the manual to indicate circuit common connected to a ground chassis).

WARNING

The WARNING sign denotes a hazard. It calls attention to a procedure, practice, or the like, which, if not correctly performed or adhered to, could result in personal injury. Do not proceed beyond a WARNING sign until the indicated conditions are fully understood and met.

CAUTION

The CAUTION sign denotes a hazard. It calls attention to an operating procedure, or the like, which, if not correctly performed or adhered to, could result in damage to or destruction of part or all of the product. Do not proceed beyond a CAUTION sign until the indicated conditions are fully understood and met.

Printing History

The current edition of this manual is indicated below. Reprints of this manual containing minor corrections and updates may have the same printing date. Revised editions are identified by a new printing date. A revised edition incorporates all new or corrected material since the previous printing date.

Changes to the manual occurring between revisions are covered by change sheets shipped with the manual. In some cases, the manual change applies only to specific instruments. Instructions provided on the change sheet will indicate if a particular change applies only to certain instruments.

This document contains proprietary information protected by copyright. All rights are reserved. No part of this document may be photocopied, reproduced, or translated into another language without the prior consent of Hewlett-Packard Company. The information contained in this document is subject to change without notice.

Instrument Identification

The power supply is identified by a unique, two-part serial number, such as, 3601A-00101. The items in this serial number are explained as follows:

Item	Description
US	The letter suffix indicates the country of manufacture, where US = USA.
3601	This is a code that identifies either the date of manufacture, or the date of a significant design change.
0101	The last five digits of the serial number (0101) is a unique number assigned to each AC Power Source.

Table of Contents

- 1. Introduction**
 - Scope 7
 - Organization 7
 - Safety Considerations..... 7
 - Related Documents 7
 - Revisions 7
 - Manual Revisions 7
 - Firmware Revisions 8
 - Electrostatic Discharge 8

- 2. Performance Tests**
 - Introduction 9
 - Test Equipment Required..... 9
 - General Measurement Techniques 9
 - Current-Monitoring Resistor 10
 - Performance Tests..... 10
 - Performance Test Record Sheets 10

- 3. Troubleshooting**
 - Introduction 19
 - Localizing the Problem 19
 - Test Equipment Required..... 19
 - List of Equipment 19
 - Troubleshooting Procedure..... 19
 - Using the *TST? Query..... 19
 - Firmware Revisions 20
 - ROM Replacement or ROM Update 20
 - Calibration Configuration Switch..... 21
 - Troubleshooting Hints..... 22
 - Switching Amplifier Output Balancing..... 22

- 4. Principles of Operation**
 - Introduction 31
 - General Description 31
 - A1, A2, A3 Switching Amplifier Modules 31
 - A4 Mother Board Assembly..... 31
 - A5 Relay Range / Sense Assembly 32
 - A6 Servo (Control) Assembly..... 32
 - A7 IEEE-488 (HP-IB) / RS-232 Interface Assembly..... 32
 - A8 Digital Signal Processing Assembly 32
 - A9 Input Power Assembly (208 Volt Input)..... 32
 - A9 Input Power Assembly (400 Volt Input)..... 32
 - A10 Auxiliary Power Supply..... 33
 - A11 Front Panel Display Assembly 33
 - A12 Input Filter Assembly 33
 - A13 Bridge Capacitor Filter Assembly..... 33
 - A14 Bias Power Supply..... 33

- 5. Replaceable Parts**
 - Introduction 35

Table of Contents (continued)

6. Diagrams	
Introduction	37
General Schematic Notes	37
Index	53

Figures

2-1. Verification Test Setup	17
2-2. Verification Test Setup	18
3-1. Bias Voltage to Switching Amplifier Assemblies	28
3-2. AC Programming Signal Path	29
4-1. HP Series 665xA/667xA Power Supply, Block Diagram	34
6-1. Mechanical Layouts.....	38
6-2. HP 6814B, 6834B, 6843A Front Frame Assembly	39
6-3. A9 208/230V AC Input Board Parts Location	40
6-4. A9 208/230V AC Input Assembly Schematic	41
6-5. A9 400V AC Input Board Parts Location.....	42
6-6. A9 400V AC Input Assembly Schematic	43
6-7. A10 Auxiliary Power Supply Board Parts Location	44
6-8. A10 Auxiliary Power Supply Assembly Schematic	45
6-9. A14 Bias Power Supply Board Parts Location.....	46
6-10. A14 Bias Power Supply Assembly Schematic	47
6-11. A5 Range/Output/Phase Relay Schematic	48
6-12. A5 Range/Output/Phase Relay Driver Schematic	49
6-13. A4 Mother Board Parts Location	50
6-14. A8 DSP Board Parts Location.....	51
6-15. A6 Servo Board Test Point Locations.....	52

Tables

2-1. Test Equipment Required	9
2-2. Performance Tests	10
2-3. Performance Test Record Form.....	13
2-4. Performance Test Record HP 6814B	14
2-4. Performance Test Record HP 6834B	15
2-4. Performance Test Record HP 6843A.....	16
3-1. Test Equipment Requirements for Troubleshooting	19
3-2. Specific Troubleshooting Procedures	21
3-3. AC Power Source Troubleshooting Procedure.....	23
3-4. A9 208/208 Input Power Supply Troubleshooting.....	25
3-5. A9 Option 400 (400V) AC Input Power Supply Troubleshooting	25
3-6. A10 Auxiliary Power Supply Troubleshooting	26
3-7. A14 Option 400 Bias Power Supply Troubleshooting	26
3-8. A4 Mother Board Troubleshooting	27
3-9. A5 Mother Board Troubleshooting	27
5-1. HP 6814B, 6834B, 6843A Replacement	35
6-1. General Schematic Notes.....	37

Introduction

Scope

Organization

This manual contains information for troubleshooting and repairing to the component level HP Model 6814B, 6834B AC Power Source/Analyzers and HP Model 6843A Regulatory Test Solution, hereafter referred to as an AC Power Source. The manual applies to both standard units and units that have Option 400. This manual is organized as follows:

Chapter	Description
Chapter 2	Performance tests
Chapter 3	Troubleshooting procedures
Chapter 4	Principles of operation on a block-diagram level
Chapter 5	Replaceable parts
Chapter 6	Diagrams

Safety Considerations

This AC Power Source is a Safety Class I instrument, which means it has a protective earth terminal. This terminal must be connected to earth ground through a power source equipped with a 4-wire, ground receptacle. Refer to the “Safety Summary” page at the beginning of this manual for general safety information. Before operation or repair, check the AC Power Source and review this manual for safety warnings and instructions. Safety warnings for specific procedures are located at appropriate places in the manual.

WARNING

Hazardous voltages exist within the AC Power Source chassis, at the output terminals, and at the analog programming terminals.

Related Documents

The following documents are shipped with your ac source:

- Quick Start Guide, to help you quickly get started using the ac source.
- User's Guide, containing detailed installation, checkout, and front panel information.
- Programming Guide, containing detailed HP-IB programming information.
- Quick Reference Card, designed as a memory jogger for the experienced user.

Revisions

Manual Revisions

This manual was written for AC Power Sources; that have the same serial prefixes (first part) as those listed on the title page and whose serial numbers (second part) are equal to or higher than those listed in the title page.

Note

1) If the serial prefix of your unit is higher than that shown in the title page then the unit was made after the publication of this manual and may have hardware and/or firmware differences not covered in this manual. If they are significant to the operation and/or servicing of the AC Power Source, those differences are documented in one or more Manual Change sheets included with this manual.

2) If the serial prefix on the unit; is lower than that shown on the title page, then the unit was made before the publication of this manual and can be different from that described here. Such differences are covered in “Appendix A - Manual Backdating Changes” in the User’s Manual.

Firmware Revisions

You can obtain the firmware revision number by either reading the integrated circuit label, or query the AC Power Source; using the HP-IB *IDN query command (see "Chapter 3 -Troubleshooting").

Electrostatic Discharge**CAUTION**

The power supply has components that can be damaged by ESD (electrostatic discharge). Failure to observe standard, antistatic practices can result in serious degradation of performance, even when an actual failure does not occur.

When working on the AC Power Source; observe all standard, antistatic work practices. These include, but are not limited to:

- working at a static-free station such as a table covered with static-dissipative laminate or with a conductive table mat (HP P/N 9300-0797, or equivalent).
- using a conductive wrist strap, such as HP P/N 9300-0969 or 9300-0970.
- grounding all metal equipment at the station to a single common ground.
- connecting low-impedance test equipment to static-sensitive components only when those components have power applied to them.
- removing power from the AC Power Source before removing or installing printed circuit boards .

Performance Tests

Introduction

This chapter provides test procedures for checking the operation of an HP Model 6814B/6834B AC Power Source/Analyzer or HP Model 6843A RTS. The required test equipment is specified and sample performance test record sheets are included. Instructions are given for performing the tests using the front panel keypad.

Test Equipment Required

Table 2-1 lists the equipment required to perform the verification tests given in this chapter.

Table 2-1. Test Equipment Required

Equipment	Characteristics	Recommended Model
Digital Voltmeter*	Resolution: 10nV @ 1V Readout: 8 1/2 digits Accuracy: <20ppm	HP 3458A
Current Monitor	0.01 ohms +/-200ppm 10W	Guildline 7320/0.01
Audio Analyzer	Input Voltage Range: 50mV to 300 V Distortion Accuracy: +/-1 db 20Hz to 20KHz Residual Distortion / Noise: -80db (0.0 1 %) 20Hz to 20KHz	HP8903A
Frequency Counter	Accuracy @ 1 KHz < 0.001%	HP5316B
Ratio Transformer*	30:1 ratio < 50ppm	
Variable -Voltage Transformer	Power: 3 phase 24 KVA Range: 180-254V 47-63 Hz 360-440V 47-63 Hz	Superior Powerstat 1156DT-3Y 0-280 50A 24.2KVA or equivalent
Load Resistors	6814B use 4 ea. 7.5 ohms > 1000W 6834B use 4 ea. 15 ohm > 1000W 6843A use 4 ea. 5 ohm > 1500W	
HP IB Controller	Full HP-IB capabilities	HP Series 200/300

* The 30:1 ratio transformer is not required for a valid MIL-STD 45662A test. The 30:1 ratio transformer is only required when a 4:1 test equipment to specification ratio is desired using a 3458A voltmeter in the 1000 volt range.

General Measurement Techniques

The following chapters provide the test procedures for verifying the HP 6814B, 6834B or 6843A's compliance with the specifications listed in Appendix A of the Users Guide. Please refer to CALIBRATION PROCEDURE or TROUBLESHOOTING if you observe out-of specification performance. The performance test specifications are listed in the Performance Test Record Card at the end of this chapter. You can record the actual measured values in the columns

provided. Select an adequate gauge wire for load tests using the procedures given in the operating manual for connecting the load.

Current-Monitoring Resistor

To eliminate output current measurement error caused by voltage drops in the leads and connections, connect the current-monitoring resistor as a four terminal device.

Performance Tests

Performance tests check all the specifications of the ac source. The various tests are grouped under Table 2-2. If more than one meter or a meter and an oscilloscope are used, connect each to the sense terminals by separate leads to avoid mutual coupling effects.

Performance Test Record Sheets

When performing the tests in this chapter, refer to the Performance Test Record sheets (Table 2-3 and Table 2-4) at the end of this chapter. Table 2-3 is for recording common information, such as test equipment used and environmental conditions. Table 2-4 is for recording the actual measurements.

Table 2-2. Voltage / Frequency Programming and Readback Accuracy

Step	Action	Normal Result
This procedure verifies that the voltage programming and HP-IB readback and front panel display functions are within specifications.		
1	Turn off ac source. Connect DVM and Ratio Transformer if used across output terminals as shown in Test Setup Figure 2-1.	
2	Turn on ac source with no load. Press [Shift] [Output], display reads *RST, press [Enter].	*RST resets ac source to known factory state.
3	Program VOLT:ALC EXT, VOLT 300, FREQ 45, CURR 10 Enable output press [Output on/off].	CV annunciator on. Output voltage at 300 volts.
4	Record output voltage / frequency measurements from DVM / front panel and frequency meter.	Output voltage / frequency measurements within specified limits on test card.
5	Program FREQ 400.	
6	Record output voltage / frequency measurements from DVM / front panel and frequency meter.	Output voltage / frequency measurements within specified limits on test card.
7	Program FREQ 1000.	
8	Record output voltage / frequency measurements from DVM / front panel and frequency meter.	Output voltage / frequency measurements within specified limits on test card.
9	Program VOLT:RANGE 150, VOLT 150, FREQ 45.	CV annunciator on. Output voltage at 150 volts.
10	Record output voltage / frequency measurements from DVM / front panel and frequency meter.	Output voltage / frequency measurements within specified limits on test card.
11	Program FREQ 400.	
12	Record output voltage / frequency measurements from DVM / front panel and frequency meter.	Output voltage / frequency measurements within specified limits on test card.
13	Program FREQ 1000.	
14	Record output voltage / frequency measurements from DVM / front panel and frequency meter.	Output voltage / frequency measurements within specified limits on test card.

Table 2-2. (Continued) CV Load Effect

Step	Action	Normal Result
This test measures the change in output voltage resulting from a change in output current from full-load to no-load or no-load to full-load.		
1	Turn off ac source. Connect DVM across output terminals (or ratio transformer if used) and 7.5 ohm for HP 6814B, 15 ohm for 6834B or 5 ohms for 6843A load resistors as shown in Test Setup Figure 2-1.	
2	Turn on ac source. Press [Shift] [Output] display reads *RST press [Enter] .	*RST resets ac source to known factory default state.
3	Program VOLT:ACL EXT, VOLT:RANGE 150 VOLT 150 CURR 20 for HP 6814B, CURR 10 for HP 6834B or CURR 32 for HP6843A. Enable output press [Output on/off] .	CV annunciator on or reduce voltage until CV annunciator come on. Output current near 20A for HP6814B, 10A for HP 6834B or 30A for HP6843A.
4	Record output voltage measurement from DVM.	
5	Open S1 (S2 or S3 if HP 6834B).	Output current near zero.
6	Record output voltage measurement from DVM.	
7	Check test result.	The difference between the DVM readings in step 4 & 6 are within the specified load effect limits.

Table 2-2. (Continued) CV Source Effect

Step	Action	Normal Result
This test measures the change in output voltage resulting from a change in ac mains input voltage from the minimum to maximum value within the line voltage specification.		
1	Turn off ac source. Connect DVM across output terminals (or ratio transformer if used) and 30 ohm for HP 6814B, 60 ohm for 6834B or 20 ohm for HP6843A load resistors as shown in Test Setup Figure 2-1.	
2	Turn on ac source. Press [Shift] [Output] display reads *RST press [Enter] .	*RST resets ac source to known factory default state.
3	Program VOLT:ALC EXT, VOLT 300, CURR 10 for HP 6814B, CURR 5 for HP 6834B or CURR 16 for HP6843A. Enable output press [Output on/off] .	CV annunciator on or reduce voltage until CV annunciator comes on. Output current near 10A for HP6814B; 5A for HP 6834B or 15A for HP6843A.
4	Adjust the variable transformer to low line condition. (180 or 360 Vac). Record voltage reading of DMM.	
5	Adjust the variable transformer to high line condition. (254 or 440 Vac). Record voltage reading of DMM.	
6	Check test result.	The difference between the DVM readings in step 3 & 5 are within the specified load effect limits.

Table 2-2. (Continued) rms Current Accuracy Test

Step	Action	Normal Result
This test verifies the measurement accuracy of the rms current readback.		
1	Turn off ac source. Connect Current Shunt, 7.5 ohm for HP 6814B, 15 ohm for HP 6834B or 5 ohm for HP6843A load resistors and DVM as shown in Test Setup Figure 2- 2.	
2	Turn on ac source. Press [Shift] [Output] display reads *RST press [Enter] .	*RST resets ac source to known factory default state.
3	Program VOLT 100, CURR 10 for HP 6814B, CURR 5 for HP6834B or CURR 15 for HP6843A. Enable output press [Output on/off] .	CC annunciator on or increase voltage till CC annunciator comes on. Output current near 10A for HP6814B; 5A for HP 6834B or 15A for HP6843A.
4	Record DMM reading and calculate rms current. Record front panel reading.	Difference between measured output current and front panel current reading is within specified limits.

Table 2-2. (Continued) Harmonic Distortion Test

Step	Action	Normal Result
This test measures the total harmonic distortion of the output sinewave at full power.		
1	Turn off ac source. Connect Audio Analyzer across output terminals (or ratio transformer if used) and 7.5 ohm for HP 6814B, 15 ohm for HP 6834B or 5 ohms for HP6843A load resistors as shown in Test Setup Figure 2-1 .	
2	Turn on ac source. Press [Shift] [Output] display reads *RST press [Enter] .	*RST resets ac source to known factory default state.
3	Program output voltage to VOLT:RANGE 150, VOLT 150, CURR 20 for HP6814B, CURR 10 for HP6834B or CURR 32 for HP6843A.	CV annunciator on or reduce voltage until CV annunciator comes on. Output current near 20A for HP6814B, 10A for HP6834B or 30A for HP6843A
4	Record the total harmonic distortion reading from the audio analyzer and front panel display.	Readings are less than maximum specified limits.

Table 2-3 Performance Test Record Form

Test Facility: _____

_____ Report No. _____
_____ Date _____
_____ Customer _____
_____ Tested By _____

Model _____ Ambient Temperature _____

Serial No. _____ Relative Humidity _____

Options _____ Nominal Line Frequency (Hz) _____

Firmware Revision _____

Special Notes:

Test Equipment Used

Description	Model No.	Trace No.	Cal. Due Date
1. Digital Voltmeter	_____	_____	_____
2. Frequency Meter	_____	_____	_____
3. Audio Meter	_____	_____	_____
4. Ratio Transformer	_____	_____	_____
5.	_____	_____	_____

Table 2-4. Performance Test Record - HP 6814B AC Power Source

Model: HP 6814B		Report No.:		Date:	
Test Description	Min Spec	Results	Max Spec	Meas Uncert **	
Voltage Programming & Readback Accuracy					
High Range@ 45 Hertz Program 300V Front Panel Display	299.250 Vrms-400mV	____V ____V	300.750 Vrms+400mV	140mV (1.2mV)	
High Range@ 400 Hertz Program 300V Front Panel Display	298.200 Vrms-400mV	____V ____V	301.800 Vrms+400mV	140mV (1.2mV)	
High Range@ 1000 Hertz Program 300V Front Panel Display	296.700 Vrms-400mV	____V ____V	303.300 Vrms+400mV	140mV (1.2mV)	
Low Range@ 45 Hertz Program 150V Front Panel Display	149.475 Vrms-325mV	____V ____V	150.525 Vrms+325mV	70mV (0.6mV)	
Low Range@ 400 Hertz Program 150V Front Panel Display	148.950 Vrms-325mV	____V ____V	151.050 Vrms+325mV	70mV (0.6mV)	
Low Range@ 1000 Hertz Program 150V Front Panel Display	148.200 Vrms-325mV	____V ____V	151.800 Vrms+325mV	70mV (0.6mV)	
CV Load Effect	Vo-0.75V	____V	Vo+0.75V		
CV Line Effect	Vo-0.3V	____V	Vo+0.3V		
Rms Current Readback	Io-0.060A	____A	Io+0.060A	1.1mA	
Total Harmonic Distortion					
Audio Analyzer	0%	____%	1%		
Front Panel Display	0%	____%	1%		
Frequency Programming & Readback Accuracy					
Program 45Hz Front Panel Display	44.985 Fo-0.014Hz	____Hz ____Hz	45.014 Fo+0.014Hz	0.9mHz	
Program 1 KHz Front Panel Display	999.89 Fo-0.110Hz	____Hz ____Hz	1000.110 Fo+0.110Hz	0.010Hz	

**Note: 1. Measurement uncertainties are only valid when using test equipment listed in Table 2-1.
 2. Voltage Programming and Readback measurements uncertainties are for a 3458A DMM in the 1000 volt range.
 3. Measurement uncertainties in parenthesis are only if a 30:1 ratio transformer is used with the 3458A DMM.

Table 2-4. (Continued) Performance Test Record – HP 6834B AC Power Source

Model: HP 6843B		Report No.:		Date:	
Test Description	Min Spec	Results	Max Spec	Meas Uncert **	
Voltage Programming & Readback Accuracy					
High Range@ 45 Hertz Program 300V Front Panel Display	299.250 Vrms-400mV	____V ____V	300.750 Vrms+400mV	140mV (1.2mV)	
High Range@ 400 Hertz Program 300V Front Panel Display	298.200 Vrms-400mV	____V ____V	301.800 Vrms+400mV	140mV (1.2mV)	
High Range@ 1000 Hertz Program 300V Front Panel Display	296.700 Vrms-400mV	____V ____V	303.300 Vrms+400mV	140mV (1.2mV)	
Low Range@ 45 Hertz Program 150V Front Panel Display	149.475 Vrms-325mV	____V ____V	150.525 Vrms+325mV	70mv (0.6mV)	
Low Range@ 400 Hertz Program 150V Front Panel Display	148.950 Vrms-325mV	____V ____V	151.050 Vrms+325mV	70mV (0.6mV)	
Low Range@ 1000 Hertz Program 150V Front Panel Display	148.200 Vrms-325mV	____V ____V	151.800 Vrms+325mV	70mV (0.6mV)	
CV Load Effect	Vo-0.75V	____V	Vo+0.75V		
CV Line Effect	Vo-0.3V	____V	Vo+0.3V		
rms Current Readback	Io-0.030A	____A	Io+0.030A	1.1mA	
Total Harmonic Distortion					
Audio Analyzer	0%	____%	1%		
Front Panel Display	0%	____%	1%		
Frequency Programming & Readback Accuracy					
Program 45Hz Front Panel Display	44.985 Fo-0.014Hz	____Hz ____Hz	45.014 Fo+0.014Hz	0.9mHz	
Program 1 KHz Front Panel Display	999.89 Fo-0.110Hz	____Hz ____Hz	1000.110 Fo+0.110Hz	0.010Hz	

**Note: 1. Measurement uncertainties are only valid when using test equipment listed in Table 2-1.
 2. Voltage Programming and Readback measurements uncertainties are for a 3458A DMM in the 1000 volt range.
 3. Measurement uncertainties in parenthesis are only if a 30:1 ratio transformer is used with the 3458A DMM

Table 2-4. Performance Test Record - HP 6843A AC Power Source

Model: HP 6843A	Report No.:	Date:		
Test Description	Min Spec	Results	Max Spec	Meas Uncert **
Voltage Programming & Readback Accuracy				
High Range@ 45 Hertz Program 300V Front Panel Display	299.250 Vrms-400mV	_____V _____V	300.750 Vrms+400mV	140mV (1.2mV)
High Range@ 400 Hertz Program 300V Front Panel Display	298.200 Vrms-400mV	_____V _____V	301.800 Vrms+400mV	140mV (1.2mV)
High Range@ 1000 Hertz Program 300V Front Panel Display	296.700 Vrms-400mV	_____V _____V	303.300 Vrms+400mV	140mV (1.2mV)
Low Range@ 45 Hertz Program 150V Front Panel Display	149.475 Vrms-325mV	_____V _____V	150.525 Vrms+325mV	70mV (0.6mV)
Low Range@ 400 Hertz Program 150V Front Panel Display	148.950 Vrms-325mV	_____V _____V	151.050 Vrms+325mV	70mV (0.6mV)
Low Range@ 1000 Hertz Program 150V Front Panel Display	148.200 Vrms-325mV	_____V _____V	151.800 Vrms+325mV	70mV (0.6mV)
CV Load Effect	Vo-0.75V	_____V	Vo+0.75V	
CV Line Effect	Vo-0.3V	_____V	Vo+0.3V	
Rms Current Readback	Io-0.090A	_____A	Io+0.090A	1.1mA
Total Harmonic Distortion				
Audio Analyzer	0%	_____%	1%	
Front Panel Display	0%	_____%	1%	
Frequency Programming & Readback Accuracy				
Program 45Hz Front Panel Display	44.985 Fo-0.014Hz	_____Hz _____Hz	45.014 Fo+0.014Hz	0.9mHz
Program 1 KHz Front Panel Display	999.89 Fo-0.110Hz	_____Hz _____Hz	1000.110 Fo+0.110Hz	0.010Hz

**Note: 1. Measurement uncertainties are only valid when using test equipment listed in Table 2-1.
 2. Voltage Programming and Readback measurements uncertainties are for a 3458A DMM in the 1000 volt range.
 3. Measurement uncertainties in parenthesis are only if a 30:1 ratio transformer is used with the 3458A DMM.

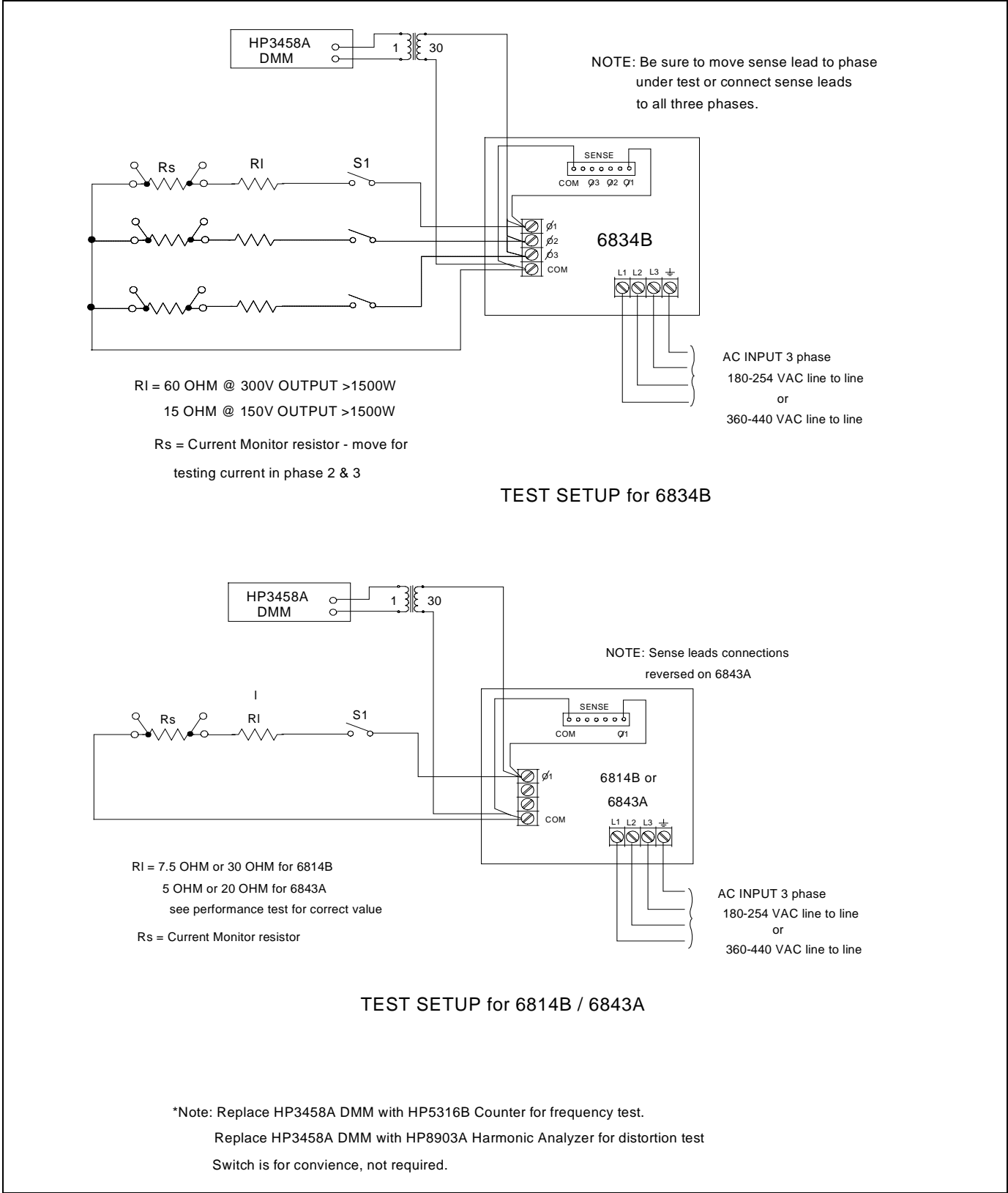

Figure 2-1. Verification Test Setup

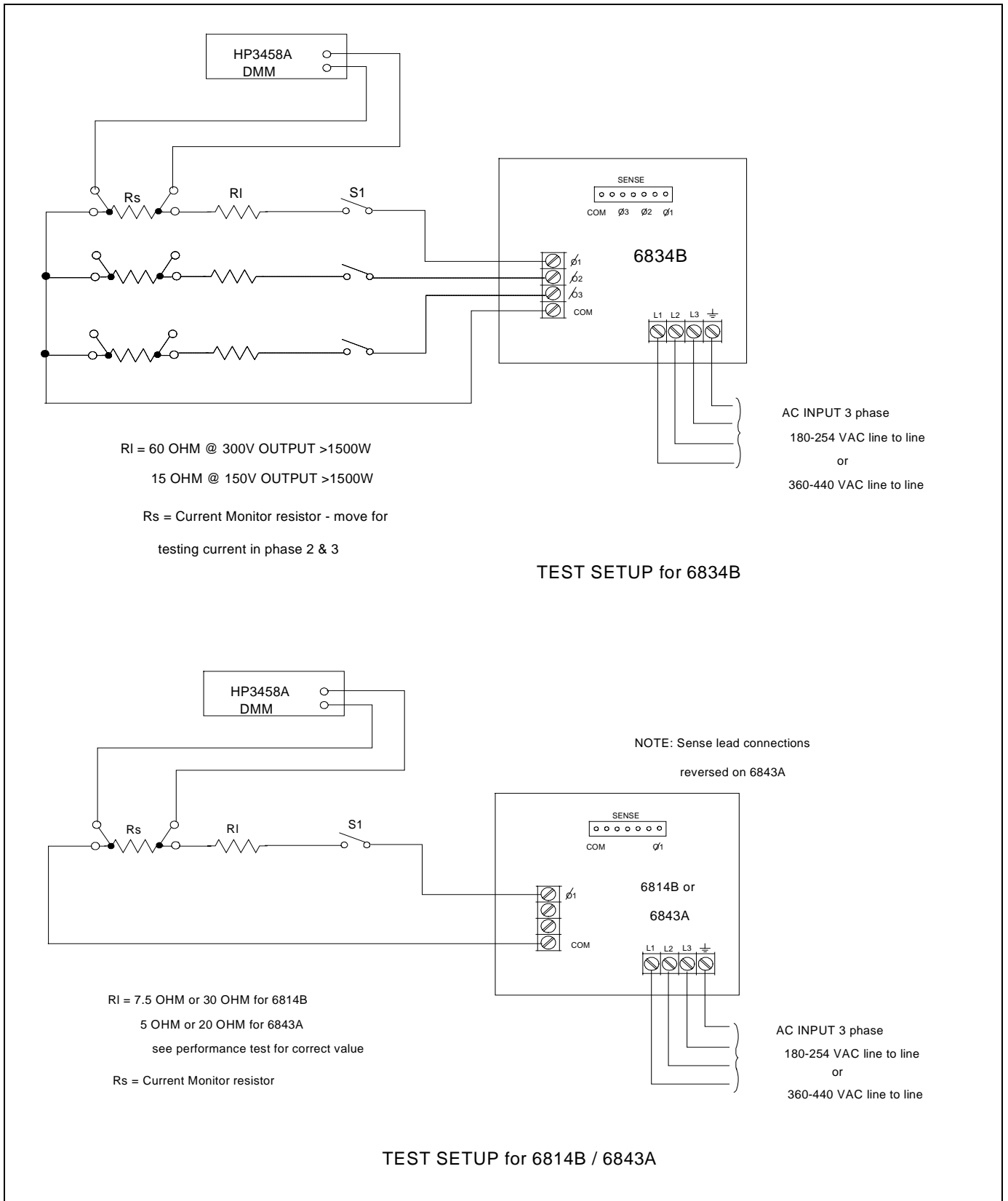

Figure 2-2 Verification Test Setup

Troubleshooting

WARNING

Shock Hazard. The troubleshooting procedure in this chapter must be performed with power applied and protective covers removed. These procedures should be done only by trained service personnel aware of the hazard from electrical shock.

CAUTION

This instrument uses components that can be damaged or suffer serious performance degradation due to ESD (electrostatic discharge). Observe standard antistatic precautions to avoid damage to components (see Chapter 1).

Introduction

Localizing the Problem

This chapter provides troubleshooting and repair information for the HP 6814B, HP 6834B AC Power Source and HP 6843A RTS. Before beginning the troubleshooting procedures, make certain the problem is in the AC Power Source and not with an associated circuit, the HP-IB controller, or the ac input lines. Without removing the covers, you can use the verification tests in chapter 2 to determine if the AC Power Source is operating normally.

Test Equipment Required

List of Equipment

Table 3-1 lists the equipment required to perform the troubleshooting procedures given in this chapter.

Table 3-1. Test Equipment Requirements for Troubleshooting

Equipment	Characteristics	Model
HP-IB Controller	Communicate with AC Source via HP-IB or RS232	HP Series 200/300 Controller or Equivalent.
Digital Voltmeter	Check voltages / resistances	HP 3458A or equivalent
Oscilloscope	Observe waveforms	HP 54504A or equivalent
Current Shunt	Check output current	0.01 ohm 10 watt
Logic Probe	Check data lines	HP 545A or equivalent

Troubleshooting Procedure

Table 3-2 gives the troubleshooting procedures to isolate a fault to a circuit board or particular circuit. See figure 6-1 for the location of the circuit boards.

Using *TST? Query

The AC Power Source executes a partial selftest by sending the HP-IB selftest query command ***TST?**. The command returns a value of zero if all tests pass. Otherwise, the command returns the error code of the first test that failed.

Firmware Revisions

The model number and then the firmware revision is displayed on the front panel for approximately 10 seconds when unit is first turned on. The firmware revision is also accessible via the HP-IB using the *IDN? query. The following sample HPBASIC program does this.

```
10 ALLOCATE L$(52)
20 OUTPUT 705;"*IDN?"
30 ENTER 705;L$
40 DISP L$
50 END
```

The computer will display the string "HEWLETT-PACKARD,<model >,0,<revision>".

ROM Replacement or ROM Update

Instruments that are being initialized for the first time or have suffered non-volatile memory corruption should be initialized with the front panel EEINIT command. To initialize the unit, perform the following:

1. Turn the unit on, then do the front panel **CAL ON** command.
2. Press 0 and 9 keys simultaneously. **EEINIT <model>** should now be displayed.
3. Scroll to the correct model number and press **ENTER**.

If the command is successful, the front panel display will go through a normal power-on sequence.

It is possible to update to newer ROM versions without destroying the calibration data. To update the unit to newer ROM revisions, perform the following.

1. Turn input power off, remove the old ROMs and install the new ROMS.
2. Turn the unit on, then do the front panel **CAL ON** command.
3. Press **0** and **9** keys simultaneously, then scroll to the **ROMUPD** command.
4. Scroll to the correct model number and press **ENTER**.

If the command is successful, the front panel display will go through a normal power-on sequence. If "OUT OF RANGE" error is displayed, then the instrument will have to be re-initialized with the EEINIT command and re-calibrated. This can occur if the instrument was previously initialized with a QA firmware revision (QA.xx.xx), or if non-volatile memory has become corrupted for any reason.

Calibration Configuration Switch

An internal set of switches control access to calibration commands. The switches are located on the A8 DSP board and are accessible by removing the top cover. Switches 1 and 2 set the calibration configuration. The three positions are:

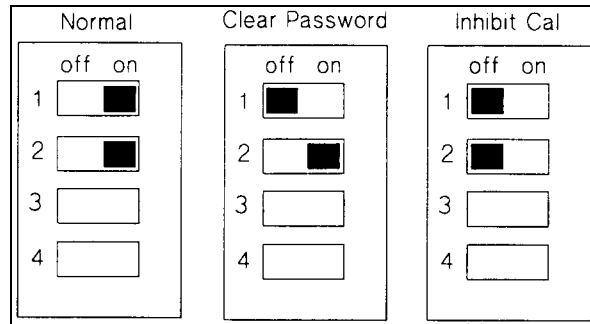

- Normal Cal** This is the default switch position. The calibration functions are accessible after entering a numeric password. The default password is 0 and is changeable by the user.
- Clear Password** The calibration password is reset to 0 and the remote programming language is set to SCPI. This option is useful if the user has forgotten the password.
- Inhibit Cal** In this position the calibration of the power source cannot be changed. All calibration commands are disabled. If the CAL ON command is sent with the switch in this position, an Out Of Range error will be displayed on the front panel. This option is useful in installations where calibration access is guarded by instrument seals.

Table 3-2. Specific Troubleshooting Procedures

Step	Symptom	Corrective Action
1.	No output voltage / front panel display and fan off	go to table 3-3
2.	No or limited output / front panel display and fan on	go to figure 3-2
3.	Turn-on Self Test Errors	
	Error 1 Non-volatile RAM RD0 section checksum failed	r1
	Error 2 Non-volatile RAM CONFIG section checksum failed	r1
	Error 3 Non-volatile RAM CAL section checksum failed	r1
	Error 4 Non-volatile RAM WAVEFORM section checksum failed	r1
	Error 5 Non-volatile RAM STATE section checksum failed	r1
	Error 6 Non-volatile RAM LIST STATE section checksum failed	r1
	Error 10 RAM selftest	r2
	Error 11 to 18 DAC self tests, 1 through 8	r2

r1- Re-initialize unit and re-calibrate. If unit still has RAM error, replace A8 DSP board. To re-initialize unit turn CAL ON, then press 0 and 9, simultaneously. Press scroll key to model number, then press Enter. When unit is re-initialized all CAL data, user-defined WAVEFORM data, and LIST data is erased.

r2 -Replace A8 DSP board.

Troubleshooting Hints

1. Read all troubleshooting instructions before attempting to troubleshoot the unit.
2. If the AC Power Source operates properly but does not deliver full output power capability, check the ac input mains fuses located on the rear panel.
3. The amplifiers, (A1, A2, A3) may be interchanged in identical models for troubleshooting purposes. The HP 6814A, 6834A, and 6843A models A1, A2, A3 amplifiers cannot be used in the HP 6814B or 6834B models. See Chapter 5, Replaceable Parts, for correct replacement amplifier.
4. The HP 6814B uses amplifiers A1 and A2 and the 6843A uses amplifiers A1, A2 and A3 connected in parallel at the output. Drawings show the connections and schematics for the HP 6834B 3 phase unit. When troubleshooting the HP 6814B, the A3 amplifier and its associated parts are deleted from specific circuit boards.
5. Troubleshooting the A9 option 400 (380 to 460 volt) Input PS is not recommended at this time. This is a 500 Vdc to 300 Vdc step down switching regulator and contains hazardous voltages.

Switching Amplifier Output Balance Adjustments

If the switching amplifiers (A1, A2 or A3) are replaced phase B and C amplifier gains may require adjustment so they better match that of phase A and current share equally when paralleled as a single phase output.

6834B Amplifier Balancing

1. With ACS off, temporarily short A5TP1 to A5TP2 on the A5 Relay board (this deactivates the paralleling relays).
2. Turn on ACS, program the output for single-phase operation, 300V, 60Hz, no load.
3. Measure the voltage from phase A output to common and from phase B output to common.
4. Adjust the phase B gain pot, A2A2R104, until phase B output matches phase A output to within 50 millivolts.
5. Measure the phase C output to common.
6. Adjust the phase C gain pot , A3A2R104, until phase C output matches phase A output to within 50 millivolts.
7. Turn off ACS and remove the short from TP1 to TP2.

6814B Amplifier Balancing

1. Turn off ACS, remove phase B amplifier. Turn on ACS. Program output voltage to 300V, 60Hz, no load.
2. Measure and note drive voltage on A6 Servo board at A6TP5 with respect to A6TP1.
3. Turn off ACS, remove phase A amplifier, install phase B amplifier in phase B slot. Turn on ACS. Program output voltage to 300V, 60Hz, no load.
4. Measure drive voltage at A6TP3 as before. Adjust phase B gain pot A2A2R104 for same drive voltage as noted in step 2, plus or minus 2 millivolts.
5. Turn off ACS, re-install phase A amplifier in phase A slot.

6843A Amplifier Balancing

1. Turn off ACS, remove phase B and C amplifiers. Turn on ACS. Program output voltage to 300V, 60Hz, no load.
2. Measure and note drive voltage on A6 Servo board at A6TP3 with respect to A6TP1.
3. Turn off ACS, remove phase A amplifier, install phase B amplifier in phase B slot. Turn on ACS. Program output voltage to 300V, 60Hz, no load.
4. Measure drive voltage at A6TP3 as before. Adjust phase B gain pot A2A2R104 for same drive voltage as noted in step 2, plus or minus 2 millivolts.
5. Turn off ACS, remove phase B amplifier, install phase C amplifier in phase C slot. Turn on ACS. Program output voltage for 300V, 60Hz, no load.
6. Measure drive voltage at A6TP3 as before. Adjust phase C gain pot A3A2R104 for same drive voltage as noted in step 2, plus or minus 2 millivolts.
7. Turn off ACS, re-install phase A and phase B amplifiers in their respective slots.

Table 3-3. AC Power Source Troubleshooting Procedures

<p>DANGER</p> <p>Lethal voltages are present when Instrument covers are removed.</p>

Step	Procedure	Indication	Action
1	Turn off ac mains, disconnect load, and configure unit for local sensing.		
2	Turn on unit and verify that ac power is on by observing if front panel display is on and fans are on.	No front panel, no fans, no relay click ?	Check F1, F2, F3 on rear panel.
3	Turn off power supply and remove top cover as follows: Remove 9 screws from top and 3 screws from each side of unit. Lift cover straight up being careful of lip on front of cover.		
4	Turn on supply and listen for clicking sound (relays energizing) on A9 Input assembly. ** See table 3-7 A14 Option 400 Bias PS verification	No relay click, relays do not energize?	See fig 6-3 & 6-4 Check A9 1/4 amp fuse. Check 24 volt bias Option 400 models See fig 6-6,6-9&6-10 Check A14 F1, F2, F3 Check 24 volt bias
5	Relays energize but no front panel display and no fans. 300 Vdc on C1. ** See table 3-4 A9 200/208 Input PS verification & table A10 Auxiliary PS verification. Option 400 500 Vdc across C9 & C10 300 Vdc on C1. ** See table 3-5 A9 Option 400 Input PS verification.	300 Vdc present ? 500 Vdc present ? 300 Vdc present ?	No 300 Vdc then See fig 6-4 Check CR1, A9F2,F3,F4 A9K1,K2,K3 300 Vdc OK See fig 6-7 & 6-8 Check A10F1 No 500 Vdc then See fig 6-6 Check CR1, A9F2,F3,F4 A9K1,K2 Check 24 V from A14 assembly No 300 Vdc then Check bias voltages from A14 assembly Replace A9 assembly
6	Relays energize, fans are on, but no front panel display.	+5VDC @ A10J6 ?	See fig 6-7 & 6-14 Check voltages at A10J6 Check +5V at A8J724-7 to A8J724-2,4 common

Table 3-3. AC Power Source Troubleshooting Procedures (continued)

Step	Procedure	Indication	Action
7	Relays energize, fans are on, but no front panel display. Press the [Shift] key a couple of times.	Shift annunciator on front panel toggles.	Check +5Vhpb and +/-15V at A10J1, J2, J3. Check communication from A8 DSP to A11 front panel. A8 DSP assembly may be defective.
8	One or more outputs are missing. The following procedures will attempt to isolate the defective assembly by tracking the bias voltages, ac program signal or ac output signal.	300 Vdc on C1. Yes 300 Vdc on C1. No All bias voltage present see fig 6-7. No	Check A4F1,F2,F3 Fuses Verify A9 Input PS see table 3-4 or 3-5. If option 400 model also verify A14 bias see table 3-7. Verify all bias voltages are present. See table 3-6.
Front panel display on, fans on. Program VOLT 100, CURR:LEV 3, Output On using front panel keypad for following procedures:			
9	Tracking ac program signal. See figure 3-2 AC Programming Signal Path.	Check A8 DSP assembly. See figure 6-14 If 1.1 Vrms not present replace A8DSP assembly Check A6 Servo assembly. See figure 6-15 If 1.6 Vrms not present replace A6 Servo assembly.	Measure 1.1 Vrms for Phase 1 A8U740-9 Phase 2 A8U770-9 Phase 3 A8U774-9 Common is J724-2,4. Measure 1.6Vrms at Phase 1 A6TP-3 Phase 2 A6TP-5 Phase 3 A6TP-7 Common at A6TP-1
10	Tracking AC output signal. Also see Table 3-9 to verify A5 Relay/Filter assembly. CAUTION – HIGH VOLTAGE To verify amplifier output connect test leads,	Check A5 Relay assembly. Relays A5K5,A5K7 and A5K8 defective ? A1,A2,A3 amplifier assemblies are good if voltage	Check 100 Vrms at Phase 1 A5TB1-1 Phase 2 A5TB1-3 Phase 3 A5TB1-4 Common at A5TB1-5 If 100 Vrms not present Then Measure 100 Vrms at Phase 1 A5L1 Phase 2 A5L2 Phase 3 A5L3 Common at A5TP-8 Measure approx. 34 Vrms between:

<p>One to outside end of C1 and the other to outside end of C3. (outside end of capacitor is end toward edge of heatsink)</p> <p>Note: See Switching Amplifier Balancing on page 22.</p>	<p>is present at C1/C3 connections (measure 100 Vrms with 300 Vrms programmed)</p> <p>Verify A4 mother board common mode choke continuity. See figure 6-13 for location of chokes.</p>	<p>A1C1 and A1C3 A2C1 and A2C3 A3C1 and A3C3 With 100 Vrms programmed.</p> <p>If voltage is present at amplifier output (C1/C3 connections) but not on A5 assembly check A5 assy.</p>
--	--	--

Table 3-4. A9 208/208 Input Power Supply Troubleshooting

Procedure	Action
<p>See figure 6-3 and 6-4 for test points and schematic.</p>	
<p>Surge Limit Circuit</p>	<ol style="list-style-type: none"> 1. Measure resistance from J1-1 to J1-7 or J1-2 to J1-8 or J1-3 to J1-6. Resistance must be greater than 100 k ohms. 2. Apply 208 volts 50/60 Hz between E4 and E7. 3. Measure resistance from J1-1 to J1-7 or J1-2 to J1-8 or J1-3 to J1-6. Resistance must be greater than 20 ohms.
<p>Bias Voltages</p>	<ol style="list-style-type: none"> 1. Apply 208 volts 50/60 Hz between E4 and E7. 2. Voltage from ZR1 cathode (+) to TP1 (-) is between 23 and 25.5 Vdc. 3. Voltage from TP3 (+) to TP1 (-) is between +11.5 and 12.5 Vdc. 4. Voltage from ZR2 cathode (+) to TP4 is between 20 and 22 Vdc. 5. Voltage from ZR3 anode (+) to TP4 must be between -20 and -22 Vdc.
<p>UVOV Detector</p>	<ol style="list-style-type: none"> 1. Apply 208 volts 50/60 Hz between E4 and E7. 2. Apply 300 Vdc (+) to E1, (-) to E2. Verify voltage from U6-7(+) to TPI(-) is greater than 9 Vdc. 3. Lower 300 Vdc to 220 Vdc. Verify that voltage at U6-7 is less than 1 Vdc. 4. Raise 300 Vdc to 395 Vdc. Verify that voltage at U6-7 is less than 1 Vdc.
<p>Phase Loss Detector</p>	<ol style="list-style-type: none"> 1. Apply 208 volts 50/60 Hz between E4 and E7. 2. Verify that voltage from U4-7(+) to TP1(-) is less than 1 Vdc. 3. Apply 300 Vdc from J1-1(+) to J1-2(-). Verify that voltage from U4-7 to TP1(-) is greater than 9 Vdc. Remove 300 Vdc. 4. Apply 300 Vdc from J1-2(+) to J1-3(-). Verify that voltage from U4-7 to TP1(-) is greater than 9 Vdc. Remove 300 Vdc. 5. Apply 300 Vdc from J1-3(+) to J1-1(-). Verify that voltage from U4-7 to TP1(-) is greater than 9 Vdc. Remove 300 Vdc.

Table 3-5. A9 Option 400 (400V) Input Power Supply Troubleshooting

Caution: A 500Vdc power source plus external capacitors and inductors are required to verify the operation of the A9 option 400 volt AC Input assembly. For safety concerns only check fuses A9F1, A9F2 and A9F3. If this does not resolve the concern then replace the A9 option 400 AC Input assembly.

Table 3-6. A10 Auxiliary Power Supply Troubleshooting

Procedure	Action
See figures 6-7 and 6-8 for test points and schematic.	
Control Circuits	<ol style="list-style-type: none"> 1. Apply 20 Vdc between TP7(+) and TP1(-). 2. Verify waveform at TP2 to TP1. 0 V to >15 V at approximately 60 kHz, duty cycle 40% to 50%. 3. Check drive to Q1 and Q4 . Connect scope common to CR13 anode, verify waveform at gate drive resistors R10 and R28 is swinging between +12Vpk and -12Vpk at approximately 60 kHz, duty cycle 40 to 50%.
Outputs	<ol style="list-style-type: none"> 1. Apply 20 Vdc between TP7(+) and TP1(-). Add a 10 ohm 25 W resistor across R13. 2. Apply 300 Vdc between J1-1,2 (+) to J1-5,6 (-). 3. Verify the 15 SW1 voltage across R13 is between 14.5 and 15.5 Vdc. 4. Verify the +5 HPIB voltage across R18 is between 4.8 and 5.2 Vdc. 5. Verify the +5V SEC voltage across R33 is between 4.2 and 5.2 Vdc. 6. Verify the fan voltage from J3-1 (+) to J3-5 (-) is between 14.6 and 15.8 Vdc. Short J4-6 to J3-5 fan voltage should now be between 17.4 and 18.9 Vdc. 7. Verify the +15 analog supply across R43 is between 14.3 and 15.5 Vdc. 8. Verify the -15 analog supply across R48 is between 14.3 and 15.5 Vdc. <p>*A lower input voltage (<300 Vdc) can be used but the expected output voltages must be recalculated.</p>

Table 3-7. A14 Option 400 Bias Power Supply Troubleshooting

Procedure	Action
See figure 6-9 and 6-10 for test points and schematic.	
Outputs	<ol style="list-style-type: none"> 1. Apply 342 V 50/60 Hz between J2-1 and J2-4. 2. From TP1 (Lo) (J1-7) to J1-8 measure 26 Vdc +/- 2V. 3. From TP1 (Lo) (J1-7) to J1-6 measure 26 Vdc +/- 2V. 4. From TP2 (Lo) (J1 -3) to J1 -4 measure 19.3 Vdc +/- 2V. 5. From TP2 (Lo) (J1-3) to J1-2 measure -19.3 Vdc +/- 2V. 6. From TP3 (Lo) (J I -11) to J1 -1 0 measure 26 Vdc +/- 2V. 7. From TP2 (Lo) (J1-3) to J1-12 measure -26 Vdc +/- 2V. <p>*A lower input voltage (<342 Vac) can be used, but the expected output voltages must be recalculated.</p>

Table 3-8. A4 Mother Board Troubleshooting

Procedure	Action														
See figure 6-13 for test points.															
Inputs	<p>The following voltage tests verify that the correct input operational voltages are available to the A4 mother board. To test for these voltages, remove the A1, A2 and A3 amplifier assemblies.</p> <p>The +300 Vdc and 300 Vdc return are shown on Fig 6-13.</p> <p>The following input voltages appear at J2, J4 and J6.</p> <table border="0" data-bbox="521 548 1162 768"> <tr> <td>IA phase A high</td> <td>IB phase A common</td> </tr> <tr> <td>2A +5V sec</td> <td>2B *OVT</td> </tr> <tr> <td>3A</td> <td>3B D common</td> </tr> <tr> <td>12A common 1</td> <td>12B common 1</td> </tr> <tr> <td>13A -15VSW</td> <td>13B -15VSW</td> </tr> <tr> <td>15A + 15VSW</td> <td>15B +15VSW</td> </tr> <tr> <td>16A + 15VSW1</td> <td>16B + 15VSW1</td> </tr> </table>	IA phase A high	IB phase A common	2A +5V sec	2B *OVT	3A	3B D common	12A common 1	12B common 1	13A -15VSW	13B -15VSW	15A + 15VSW	15B +15VSW	16A + 15VSW1	16B + 15VSW1
IA phase A high	IB phase A common														
2A +5V sec	2B *OVT														
3A	3B D common														
12A common 1	12B common 1														
13A -15VSW	13B -15VSW														
15A + 15VSW	15B +15VSW														
16A + 15VSW1	16B + 15VSW1														
Continuity check	Verify common mode inductors (L1 thru L6) continuity. See A4 Mother Board Parts Location on Figure 6-13.														

Table 3-9. A5 Relay / Filter Board Troubleshooting

Procedure	Action
See figure 6-11 and 6-12 for test points.	
Range relays	<p>Program VOLT 50, CURR:LEV 3, Output On.</p> <p>Program high range: Measure 25 volts from J2-1 to J2-3, J2-2 to J2-4, J2-5 to J2-7, J2-6 to J2-8, J2-9 to J2-11 and J2-10 to J2-12.</p> <p>Program low range: Measure 50 volts from J2-1 to J2-3, J2-2 to J2-4, J2-5 to J2-7, J2-6 to J2-8, J2-9 to J2-11 and J2-10 to J2-12.</p>
Output enable / disable Relays	Measure 50 volts from TB1-1 to TB1-6, TB1-3 to TB1-6 and TB1-4 to TB1-6. If voltages are not available, test voltage between relays K5, K7, K8 common terminal to determine defective relay.
Sense relays	<p>Program ACL:INT: Measure greater than 10 megohms from R43 to K5 common, R44 to K7 common, R45 to K8 common and R46 to K9 common.</p> <p>Program ACL:EXT: Measure approximately 105 Kohms from R43 to K5 common, R44 to K7 common, R45 to K8 common and R46 to K9 common.</p>

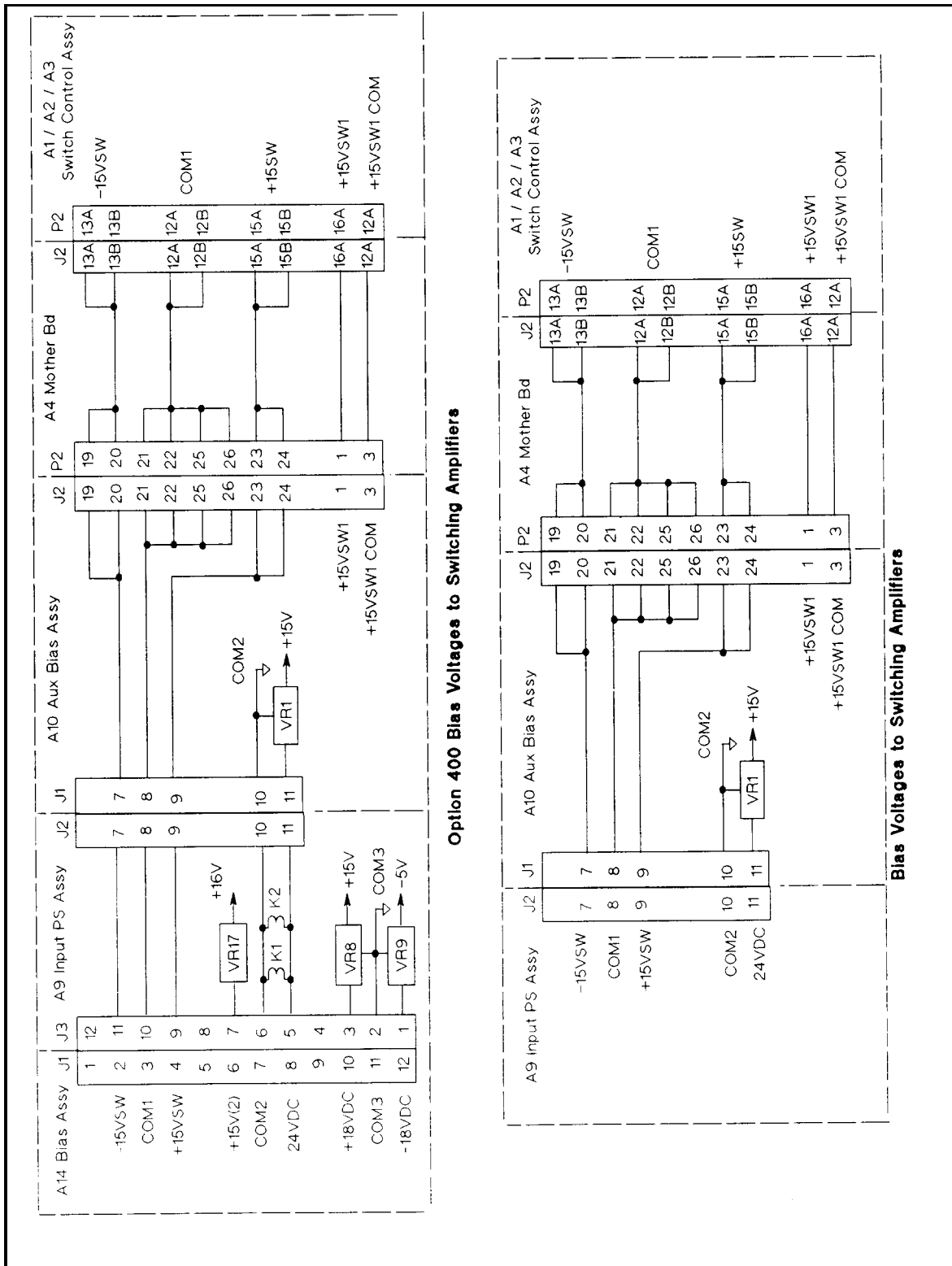

Figure 3-1. Bias Voltage to Switching Amplifier Assemblies

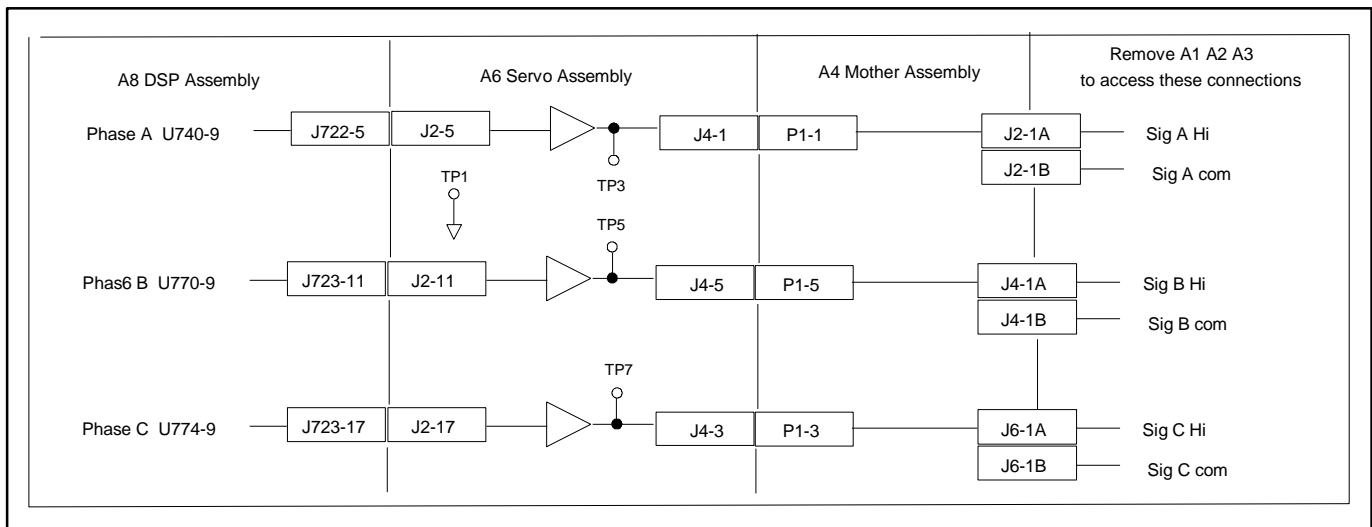

Figure 3-2. AC Programming Signal Path

Principles of Operation

Introduction

Figure 4-1 (at end of this chapter) is a block diagram showing the major circuits within the ac source. The ac source consists of the following modules:

A1, A2, A3	Switching Amplifiers Modules
A4	Mother Board Assembly
A5	Range Relay and Filter Assembly
A6	Servo (Control) Assembly
A7	IEEE488 (HP-IB) & RS232 Interface Assembly
A8	Digital Signal Processing (DSP) Assembly
A9	Input Power Assembly
A10	Auxiliary Power Supply Assembly
A11	Front panel Assembly
A12	Input Filter PC Assembly
A13	Bridge Capacitor Filter Assembly
A14	Bias Power Supply (option 400 only)

General Description

The 3 phase input power is connected to TBI on the rear panel, then routed through F1, F2 and F3 to the RFI filter, FLI, to relay KI. The 3 phase input power is also connected to the A9 Input power assembly. When relay KI closes the 3 phase input is connected to power rectifier CRI, L1 and C1 to create 300 Vdc required by the power amplifiers A1, A2 and A3. The amplifier assemblies in concert with the output filter and range relays produce the programmed waveform at the programmed frequency and voltage. The 300 Vdc is also used by the A10 Auxiliary power supply board to produce the bias voltages required by support circuits.

A1, A2, A3 Switching Amplifier Modules

The switching amplifier modules consist of a heat sink assembly, control board and power board. The 3 amplifier modules are identical and can be interchanged for troubleshooting assistance. The amplifier assemblies can only be replaced as a complete assembly, they are not repairable to the component level. The HP 6814B uses 2 amplifier assemblies connected in parallel to provide 3000 watts single phase AC output power. The HP 6834B uses 3 amplifier assemblies connected in a 3-phase configuration with each amplifier providing 1500 watts AC output power per phase. The 6843A uses three amplifiers connected in parallel to provide 4800 watts single phase AC output power. When an amplifier assembly is replaced it will be necessary to balance the amplifier, see paragraph on page 3-4 Switching Amplifier Output Balance Adjustments. Amplifiers from [6814A, 6834A] or [6843A] or [6814B, 6834B] Models are NOT INTERCHANGABLE. See Chapter 5 Replaceable Parts listing for correct replacement assembly.

A4 Mother Board Assembly

The A4 mother board interconnects the A1, A2 and A3 amplifier assemblies with the A6 servo assembly, the 300 Vdc rail voltage and the +/-15 Vdc bias supply. There are 10 amp fuses located in the +300 Vdc line to each amplifier assembly. The HP 6814B and 6834B A4 assemblies are not interchangeable.

A5 Relay Range / Sense Assembly

The A5 assembly consists of the output voltage filters, the output voltage range relays A5K1, A5K2 and A5K3, the output voltage disconnect relays A5K5, A5K6, A5K8 A5K9 and remote sense relays A5K4, A5K7 and all associated circuits. It also interconnects the A7 HPIB/RS232 assembly, A11 front panel assembly and A8 DSP assembly with each other and the trigger and DFI/RI signals. The HP 6814B and 6834B A5 assemblies are not interchangeable.

A6 Servo (Control) Assembly

The A6 servo or control assembly consists of the gate control circuits for the A1, A2 and A3 power amplifiers where required. It also contains the voltage and current control amplifiers and receives the voltage and current programming information from the A8 DSP assembly. It interconnects the range and protection signals between the A5 and A8 assemblies. This assembly is not component level repairable. The HP 6814B and 6834B A6 assemblies are not interchangeable.

A7 IEEE488 (HPIB) / RS232 Interface Assembly

The A7 interface contains the CPU and logic circuits for communicating with either an HPIB or RS232 computer/controller. This assembly is not component level repairable. This assembly is interchangeable with all AC power sources.

A8 Digital Signal Processing Assembly

The A8 DSP board contains the CPU, ROMs, Digital to Analog and Analog to Digital circuits to control the output voltage and output current settings. The A8 board also contains all the logic circuits for generating arbitrary waveforms, frequency changes and phase control. At power on the DSP board performs a self-test and will report a failure via the front panel display. This assembly is not component level repairable and is not interchangeable between an HP 6814B and 6834B.

A9 Input Power Assembly - (208 volt input)

The A9 input power assembly provides a current limit circuit to initially charge C1 to 300 Vdc, a phase loss detection circuit, the undervoltage / overvoltage detection circuits, and +/- 15VSW to the A10 auxiliary power supply assembly. When S1, on/off switch, is closed a single phase is used to power two bias transformers generating the +/-15 Vdc, 12 Vdc for the protection circuits and 24 Vdc to the current limit relays K1, K2 and K3. There are 4 fuses on the A9 board. Fuse A9F1 is in series with S1 on/off switch, if A9F1 is open the HP 6834B will not function in any form. The remaining 3 fuses, A9F2, A9F3 and A9F4 are in series with the current limit resistors and relays. If all 3 fuses are open the unit will not function and if 1 or 2 fuses are open the phase loss status bit be true and full output power will not be available. This assembly is not component level repairable except for fuses. This assembly is interchangeable between an HP 6814B and 6834B.

A9 Input Power Assembly - (400 volt input)

The A9 input power assembly provides a current limit circuit to initially charge C9 and C10 to 550 Vdc, a step-down switching regulator to power the +300V on C1, a phase loss detection circuit and the undervoltage / overvoltage detection circuits. When S1, on/off switch, is closed a single phase is used to power three bias transformers on the A12 Bias board, The A12 Bias board provides +16 Vdc, +15 Vdc, -5 Vdc, 12 Vdc for the protection circuits and 24 Vdc to the current limit relays K1 and K2. There are 3 fuses on the A9 board. The 3 fuses, A9F2, A9F3 and A9F4 are in series with the current limit resistors and relays. If all 3 fuses are open the unit will not function and if 1 or 2 fuses are open the phase loss status bit be true and full output power will not be available. This assembly is not component level repairable except for fuses. This assembly is interchangeable between a 6814B and 6834B.

A10 Auxiliary Power Supply

The 300 Vdc is used by the A10 board to generate the bias voltages. The 300 Vdc input line is fused by a 1 ampere subminiature fuse, A10F1. The A10 supplies an isolated +5 Vdc for the A7 HPIB/RS232 interface board and A11 front panel board. The + 15 VSW dc to the A4 mother board via J2, the +/-15V and +5Vsec to the A6 servo board via J4 and +5V sec to the A8 DSP board via J5. It also supplies the 12-24 Vdc for the fan speed control. All secondary bias winding are fused with 1 ampere subminiature fuses A10F2 through A10F7. This assembly is not component level repairable except for fuses. This assembly is interchangeable between an HP 6814B and 6834B.

A11 Front Panel Display Assembly

The A11 assembly contains the display assembly, keypad, rotary pulse generators (RPG) and digital logic circuits, CPU and ROM. This assembly is not component level repairable. This assembly is interchangeable between an HP 6814B and 6834B.

A12 Input Filter Assembly

The A12 assembly contains resistor / capacitor networks connected line to line to reduce any magnetic noise from being conducted back into the AC input mains.

A13 Bridge Capacitor Filter Assembly

The A13 assembly contains capacitors and surge protectors connected line to line and a common mode inductor and surge protector connected in series with the + 300 Vdc bus. The filter is connected to reduce conducted and radiated noise generated by the three-phase rectifier.

A14 Bias Power Supply

This assembly is only used with the 400 volt input option. The A12 board provides the ac voltages required for the low voltage regulators and the +24 Vdc for the current limit relays on the A9 board. It also provides the +/-15VSW to the A10 Auxiliary board. Fuse F1 for the +24 Vdc, a LED will light on the A12 board if F1 opens. Fuse F2 and F3 for the +24 Vdc and + 16 Vdc. F4 and F5 for the +/-15VSW. F6 and F7 for the + 15 Vdc / -5 Vdc regulators. This assembly is interchangeable between an HP 6814B and 6834B.

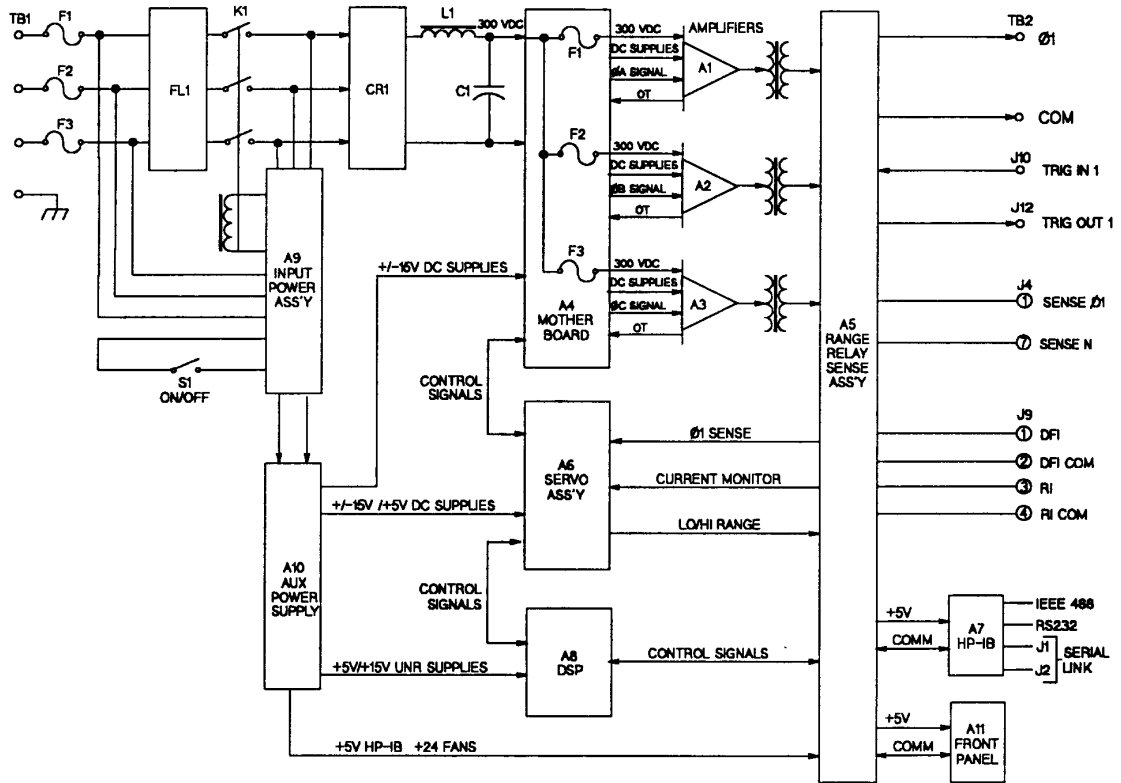

Figure 4-1. AC Power Source, Block Diagram

Replaceable Parts

Introduction

This section lists the replaceable electrical and mechanical parts for the HP 6814B and 6834B AC Power Source/Analyzers and 6843A RTS.

Table 5-1. HP 6814B, 6834B & 6843A Replacement Assemblies

Reference Desig.	Model / Input Option	HP Part No.	Description
ELECTRICAL PARTS			
A1-A3	6814B, 6834B	5063-3415	Output Switching Amplifier Assembly
A1-A3	6843A	5060-9696	Output Switching Amplifier Assembly
A4	6814B	5060-9695	Mother Board Assembly
A4	6834B, 6843A	5060-9673	Mother Board Assembly
A5	6814B	06814-69001	Relay / Filter Assembly
A5	6834B	06834-69001	Relay / Filter Assembly
A5	6843A	06843-69021	Relay / Filter Assembly
A6	6814B	06814-69002	Servo (Control) Assembly
A6	6834B	06834-69002	Servo (Control) Assembly
A6	6843A	5060-9607	Servo (Control) Assembly
A7	6814B, 6834B	5060-3594	HP-IB/RS232 Interface Assembly
A7	6843A	5063-2376	HP-IB/RS232 Interface Assembly
A8	6814B	5063-3455	DSP (1P) Assembly
A8	6834B	5063-3456	DSP (3P) Assembly
A8	6843A	5063-2368	DSP (1P) Assembly
A9	6814B,6834B,6843A #208	5060-9671	AC Input Assembly
A9	6814B,6834B,6843A#400	5060-9675	AC Input Assembly
A10	All Models	5060-9672	Auxiliary Power Supply Assembly
A11	All Models	5060-3596	Front panel PC Assembly
A12	6814B,6834B#208	5060-9689	Input Filter Assembly
A12	6814B,6834B#400	5060-9688	Input Filter Assembly
A13	6814B,6834B#208	5063-2390	Bridge Filter Capacitor Assembly
A13	6814B,6834B#400	5063-2391	Bridge Filter Capacitor Assembly
A14	6814B,6834B#400	5060-9687	Bias Power Supply Assembly
A15	6814B, 6834B	5060-3597	BNC Assembly
A11G1,G2	All Models	0960-0912	RPG
A8U724	All Models	1818-4441	SRAM
A4F1-A4F3	All Models	2110-0911	15A-500V (Buss KLM-15)
A7F1	"	2110-0665	1A-250V
A9F1	"	2110-0004	1/4A-250V
A9F2-A9F4	"	2110-0007	1A-250V Slo Blo
A10F1	"	2110-0991	2A-250V Subminature
A10F2 – A10F7	"	8159-0005	Zero Ohm Resistor

Table 5-1. HP 6814B, 6834B & 6843A Replacement Assemblies (continued)

Reference Desig.	Model / Input Option	HP Part No.	Description
ELECTRICAL PARTS			
	All Models	0360-2848	AC Input Terminal Block
	All Models	0360-2849	AC Output Terminal Block
	All Models	0370-3298	Knob
	All Models	1252-1488	4 Terminal DFI/RI Connector Plug
	All Models	1252-3698	7 Terminal Sense Connector Plug
	All Models	1510-0444	Terminal – ground rear panel
	All Models	2110-0397	Fuse holder – rear panel
	All Models	3101-3088	Switch
	All Models	3160-0306	Fan – tubeaxial – 4”
	All Models	3160-0929	Fan – blower – 6”
	All Models	5001-6794	Blinder
	All Models	5001-6796	Label, Front Panel Upper & Lower
	All Models	5001-9810	Cover, Fuse Holders
	All Models	5001-9811	Cover, AC Output Terminal Block
	All Models	5001-9838	Cover, Top
	All Models	5001-9839	Cover, Side
	All Models	5001-9872	Cover, AC Safety w/cable clamp
	6814B/6834B	5002-1503	Rear Panel
	6843A	5001-9870	Rear Panel
	All Models	5040-1698	Front Frame Lower
	All Models	5040-1702	Keypad
	All Models	5040-1703	Front Frame Upper
	All Models	5041-8801	Foot
	All Models	5063-2310	Rack Mount Slide Kit
	All Models	5080-2333	Window
	6814B,6834B	5080-2455	Label, Rear Panel
	6843A	5080-2334	Label, Rear Panel
	All Models	5962-0883	Guide, Quick Start
	All Models	5962-0885	Card, Quick Reference
	All Models	5962-0887	Guide, Users
	All Models	5962-0889	Guide, Programming
	6843A	5962-0831	Guide, EN61000-3-2, EN61000-3-3, 60555
FL1	All Models	9135-0493	Filter - RFI
	6814B	06814-80002	6814B Nameplate (Superbug)
	6834B	06834-80002	6834B Nameplate (Superbug)
	6843A	06843-80001	6843A Nameplate (Superbug)

Note: See figure 6-2 for front frame mechanical assembly

Diagrams

Introduction

This chapter contains drawings and diagrams for troubleshooting and maintaining the HP 6814B and 6834B AC Power Source/Analyzers. Unless otherwise specified in the drawings, a drawing or diagram applies to all models and input voltage options.

Table 6-1. General Schematic Notes:

1. All resistors are in ohms $\pm 1\%$, 1/8 W, unless otherwise specified.
2. All capacitors are in microfarads unless otherwise specified.
3. Unless otherwise noted, bias connections to integrated-circuit packages are as follows:

	Common	+ 5 V
14-pin packages	pin 7	pin 14
16-pin packages	pin 8	pin 16
20-pin packages	pin 10	pin 20

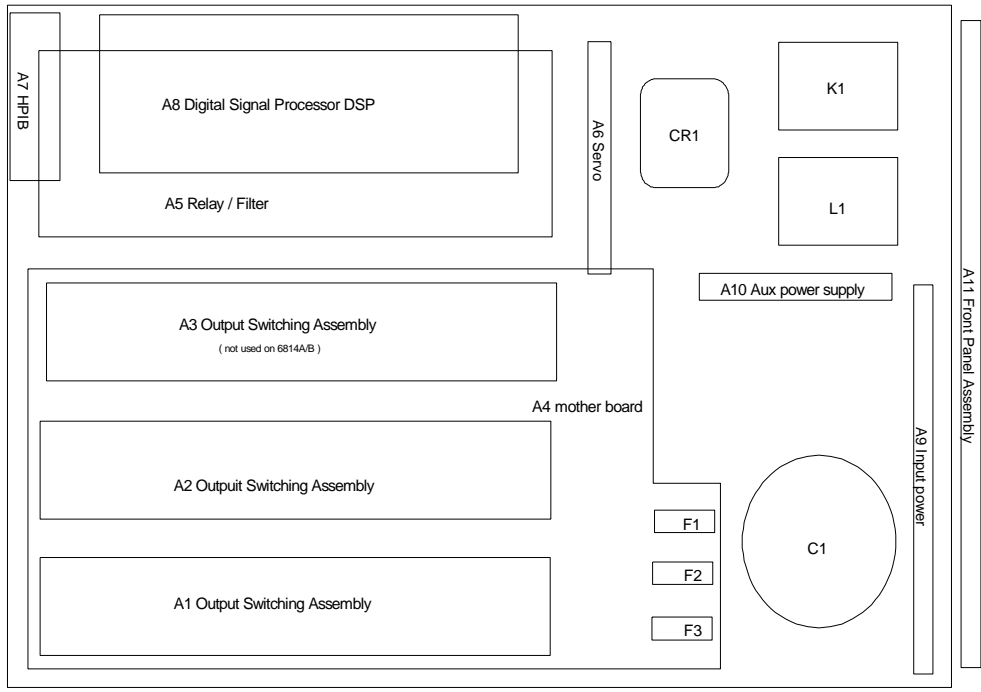

6814B, 6834B, 6843A Mechanical Layout 208/230 Volt Input

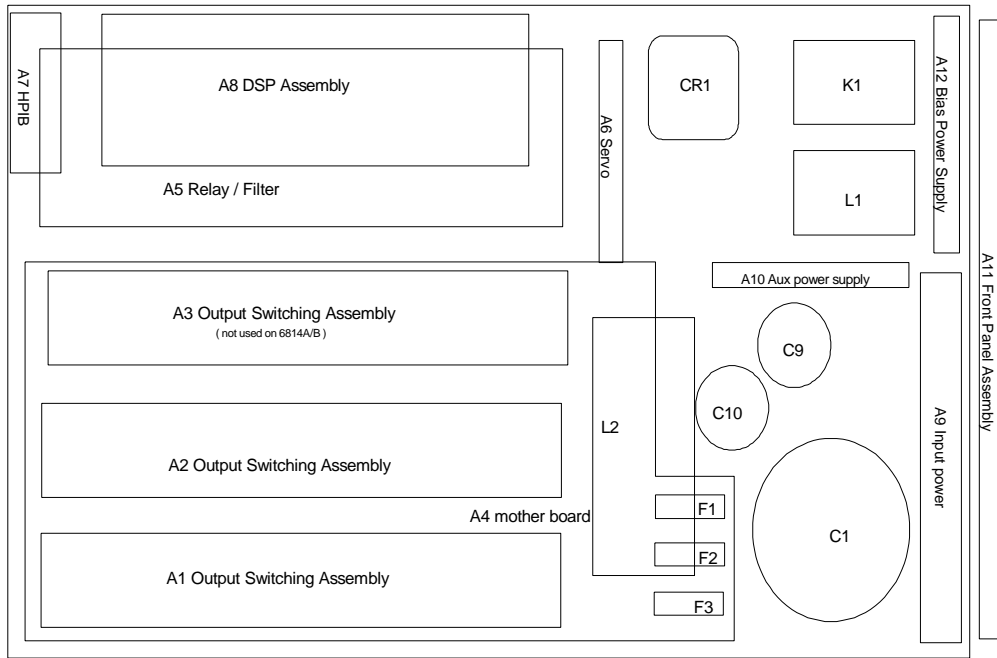

6814B, 6834B, 6843A Mechanical Layout 400 Volt Input

Figure 6-1. Mechanical Parts

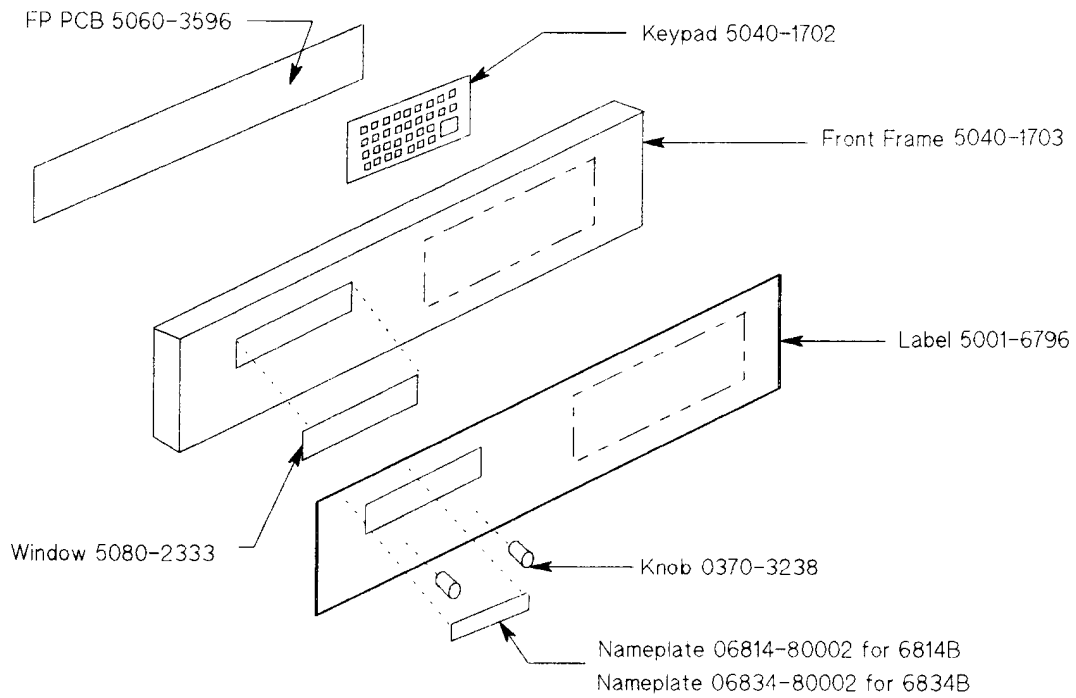

Upper Panel

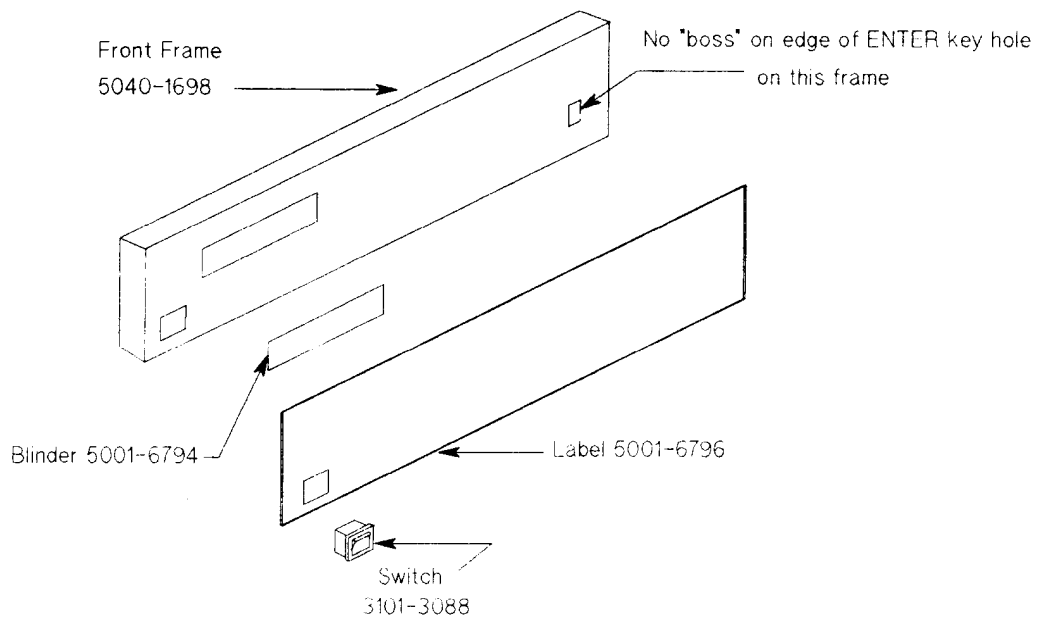

Lower Panel

Figure 6-2. 6814B, 6834B and 6843A Front Frame Assembly

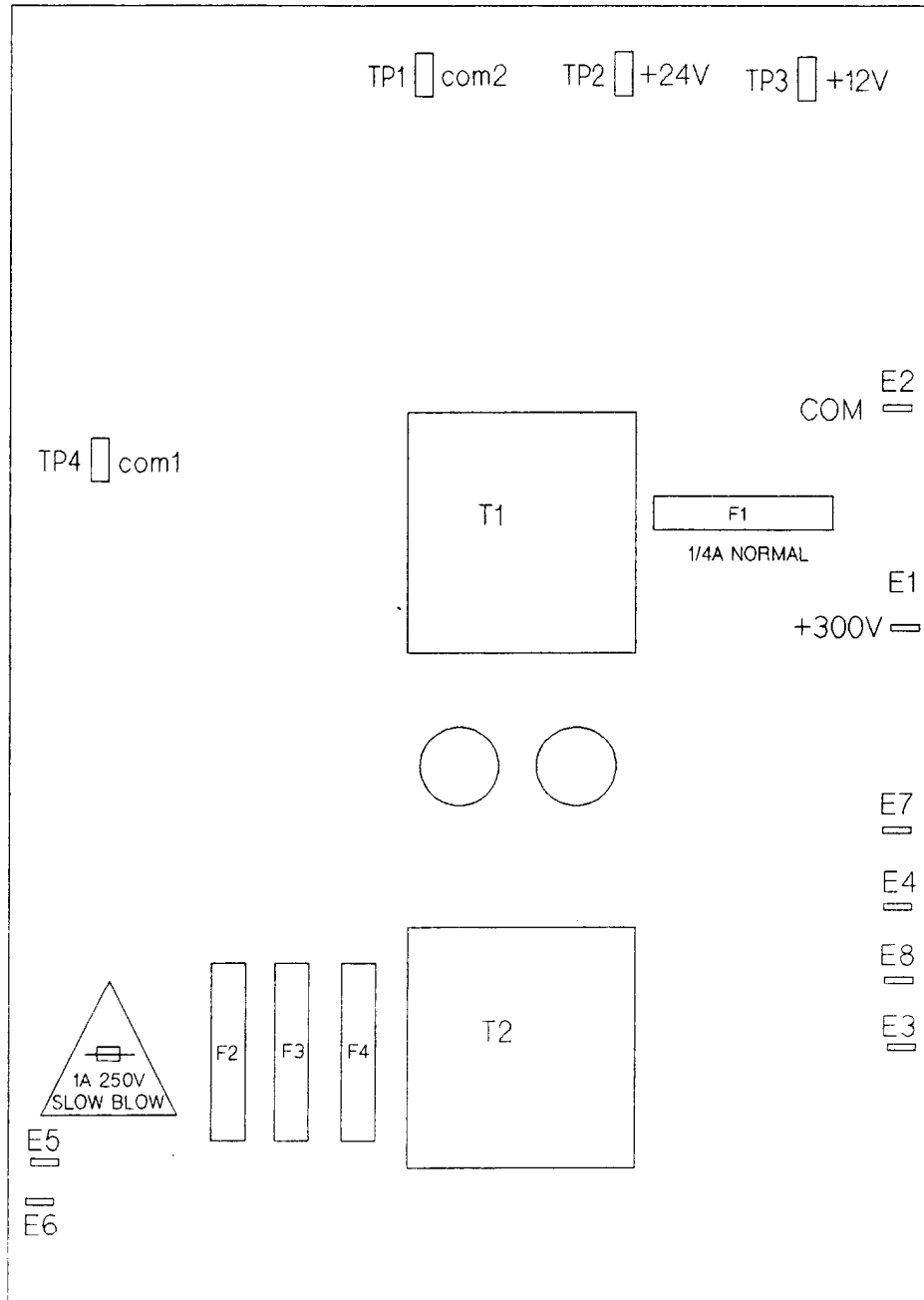

Figure 6-3. A9 208/230V AC Input Board Parts Location

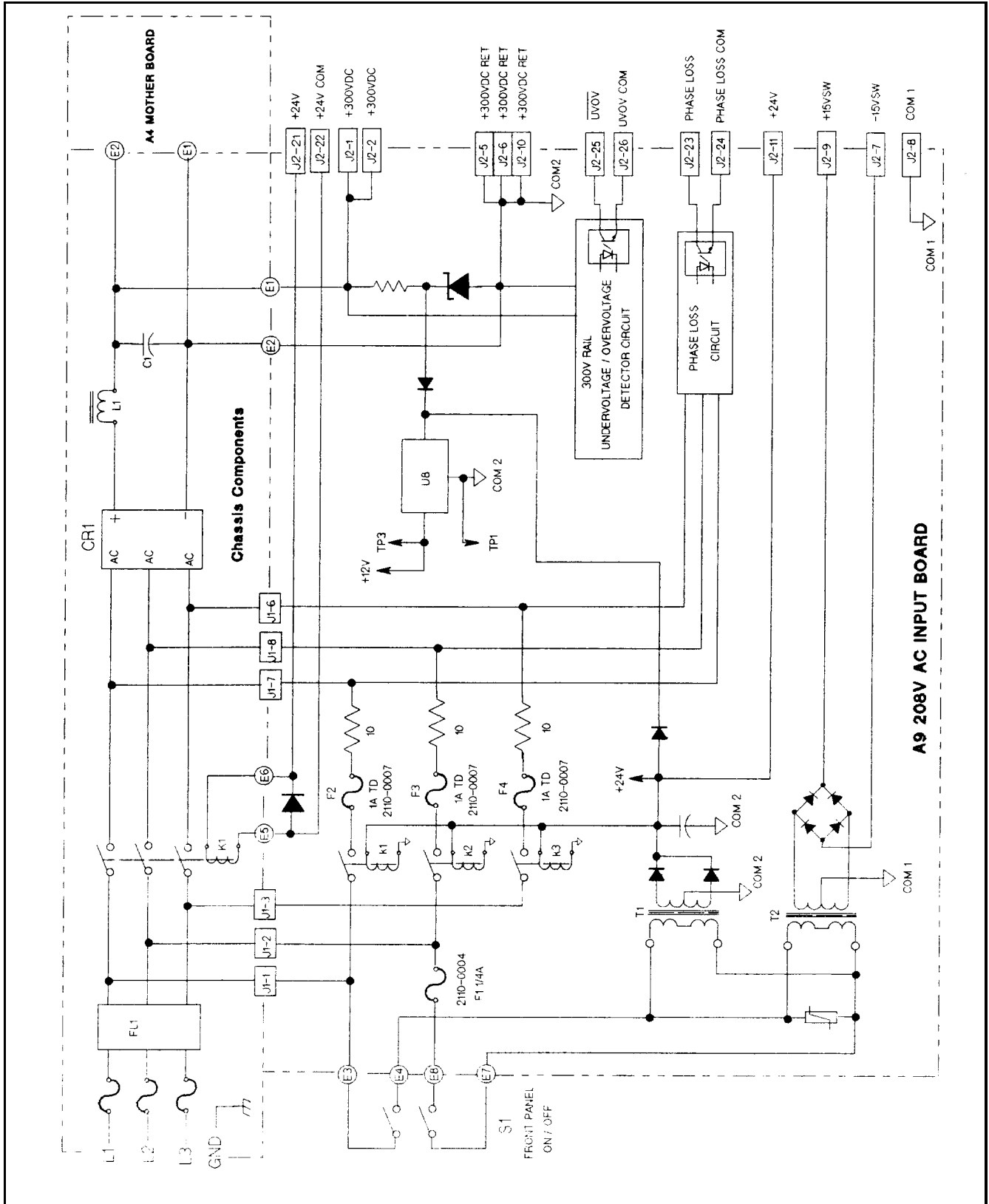

Figure 6-4. A9 208/230V AC Input Assembly Schematic

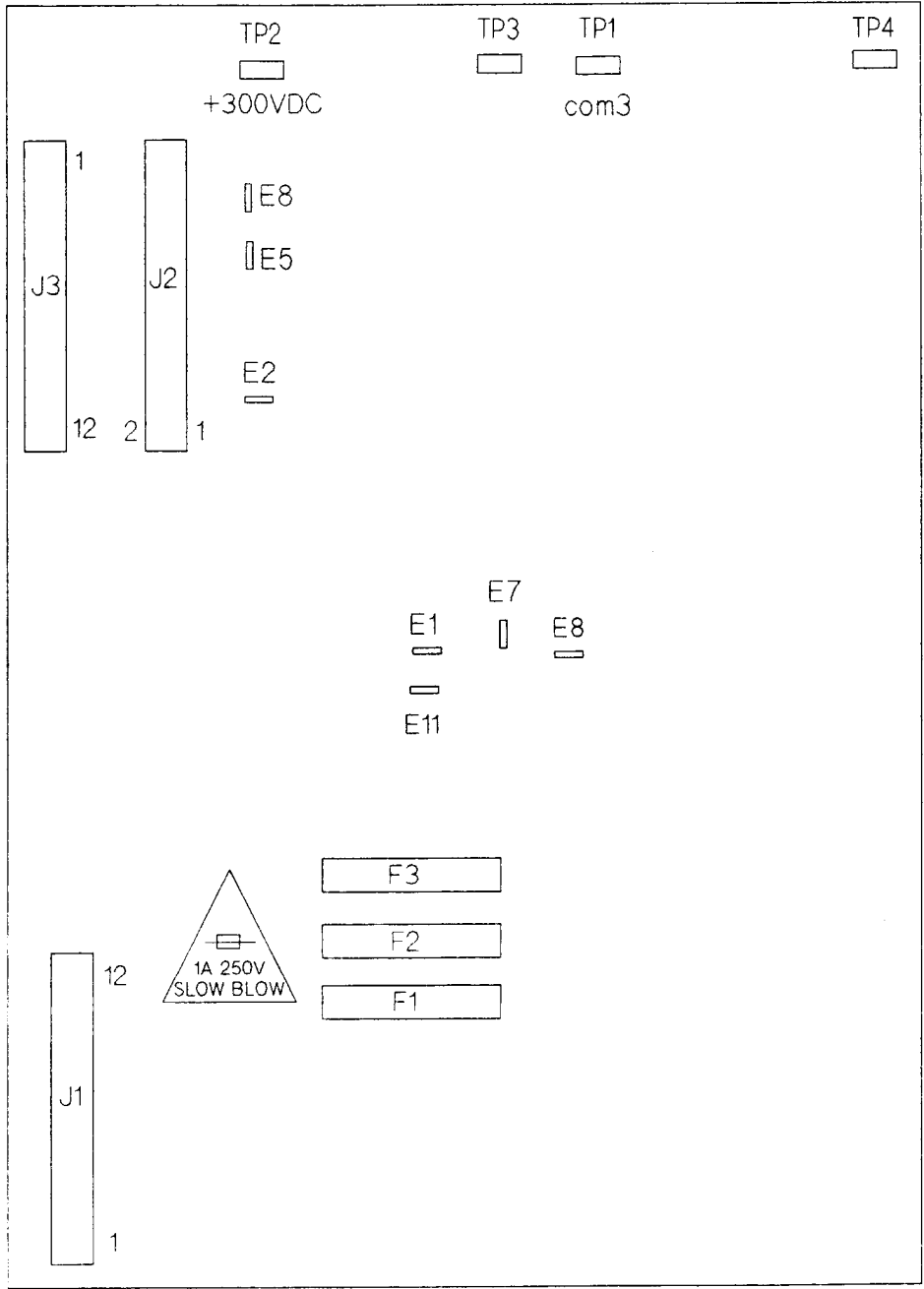

Figure 6-5. A9 400V AC Input Board Parts Location

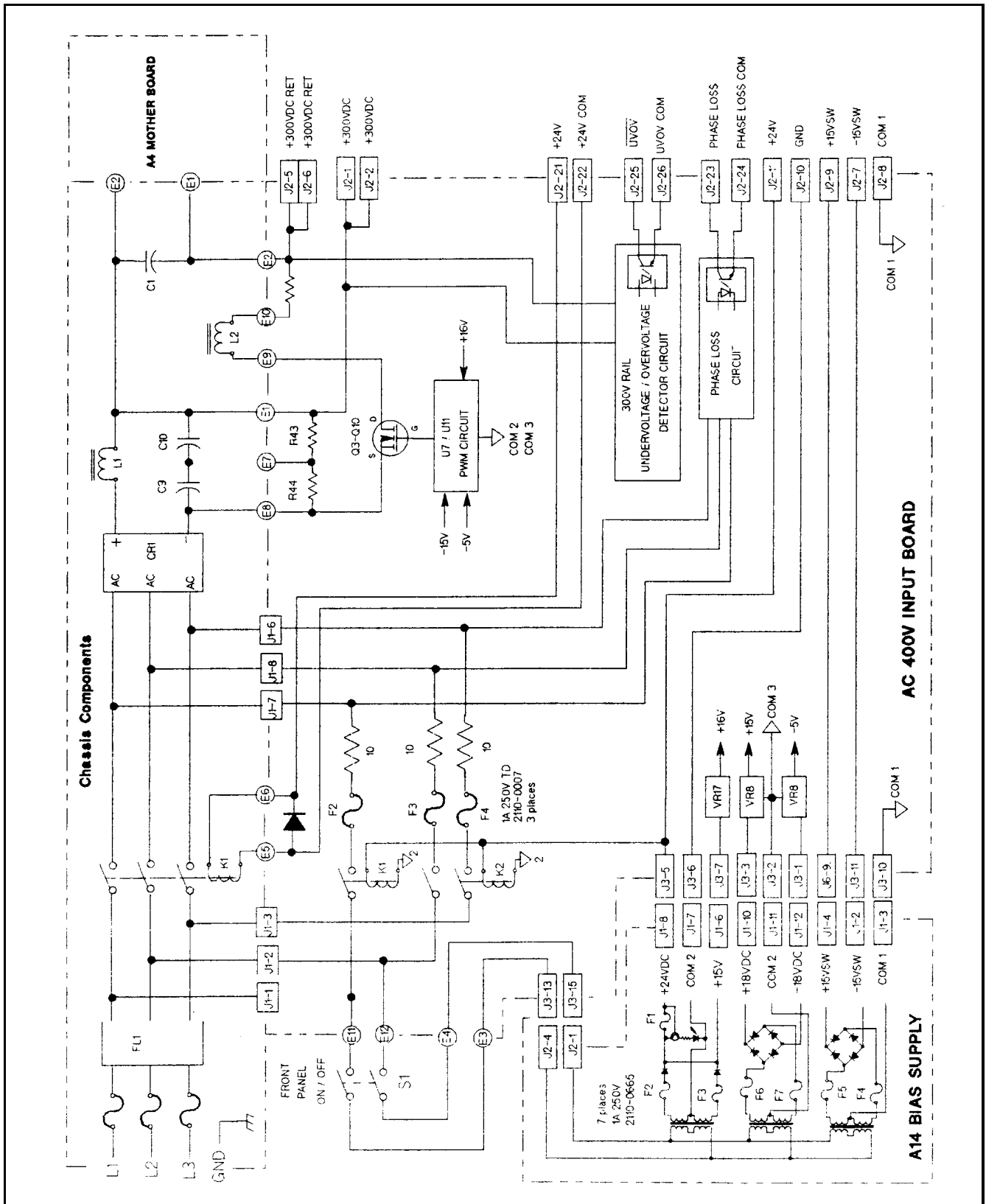

Figure 6-6. A9 400V AC Input Assembly Schematic

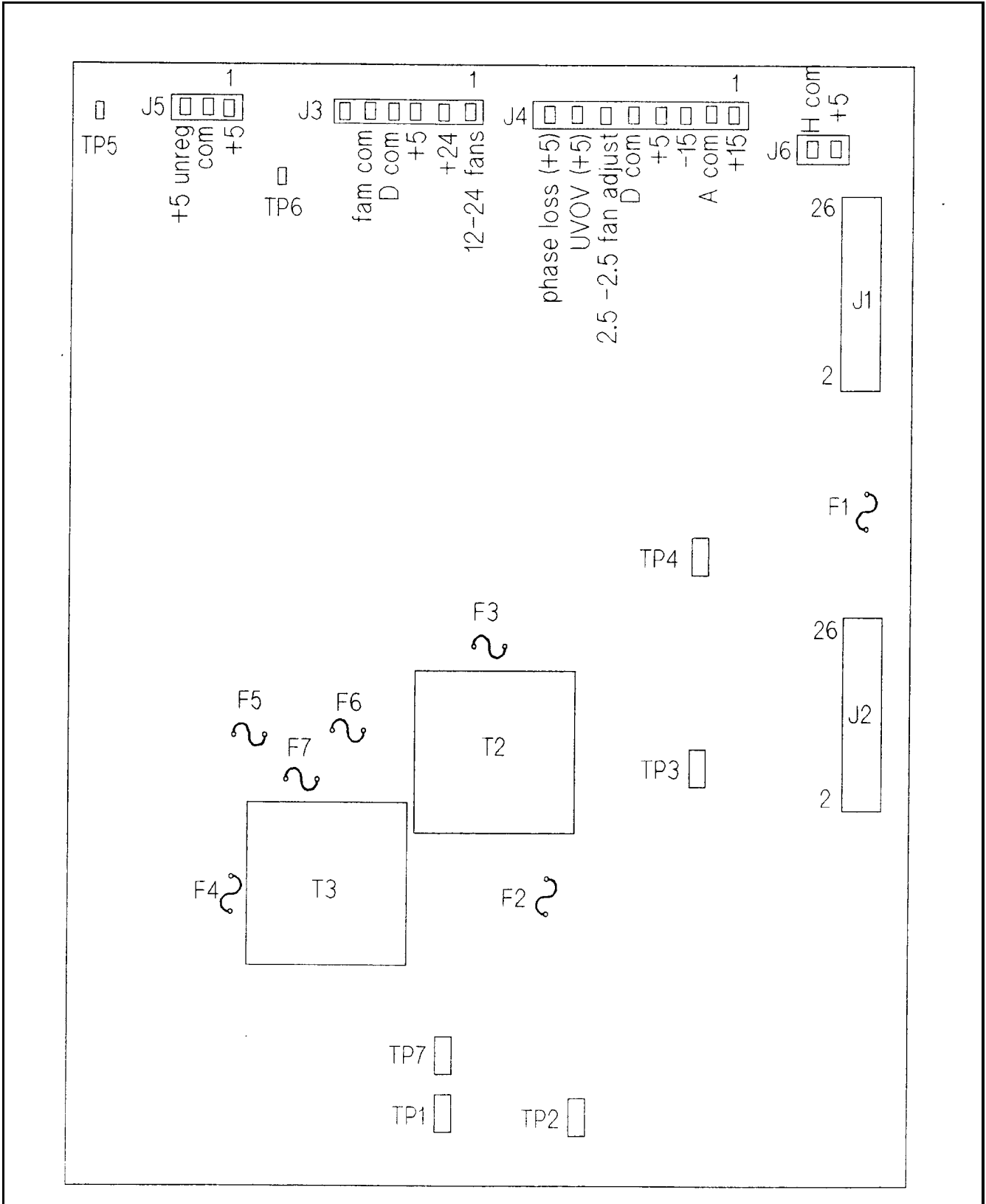

Figure 6-7. A10 Auxiliary Power Supply Board Parts Location

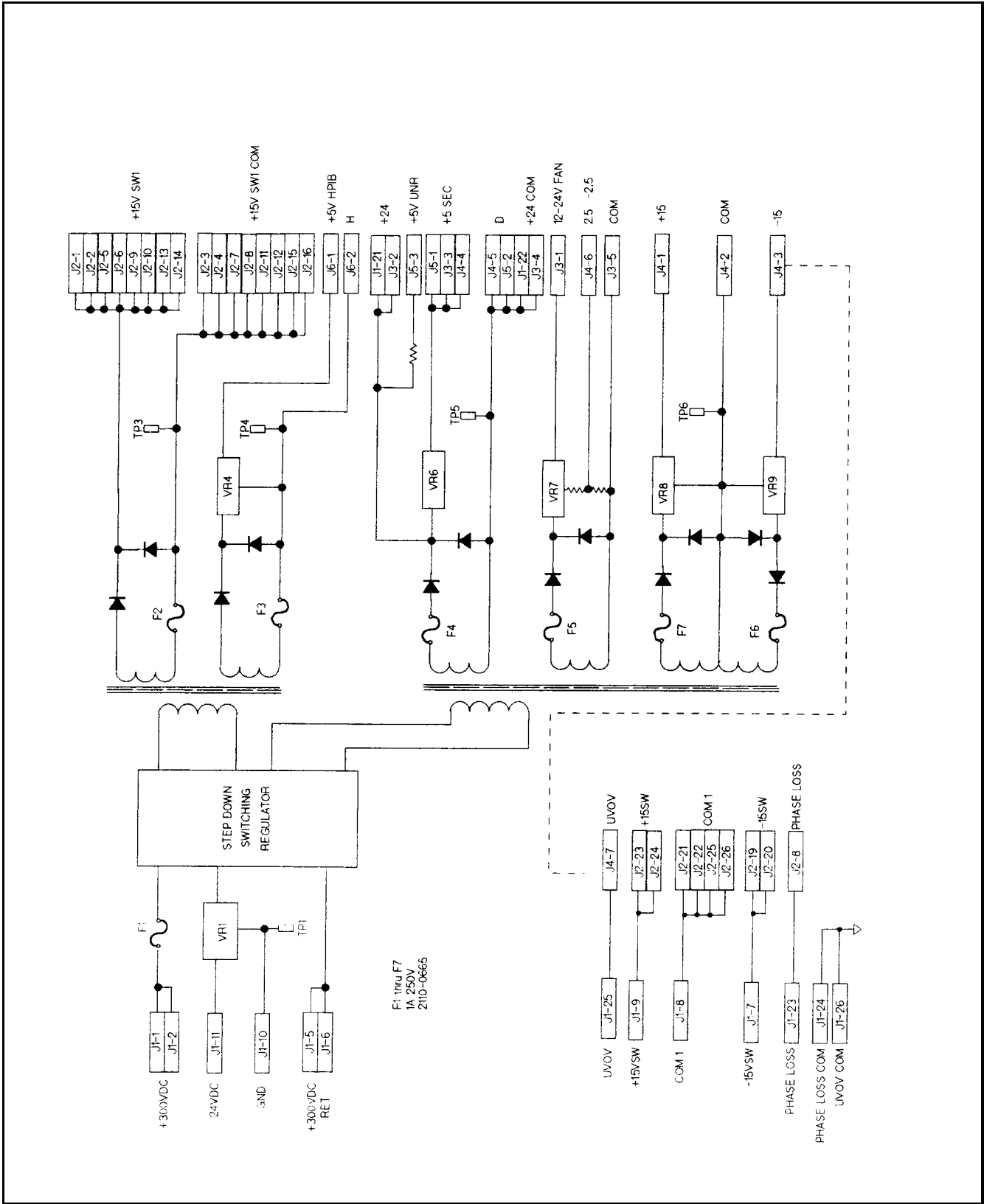
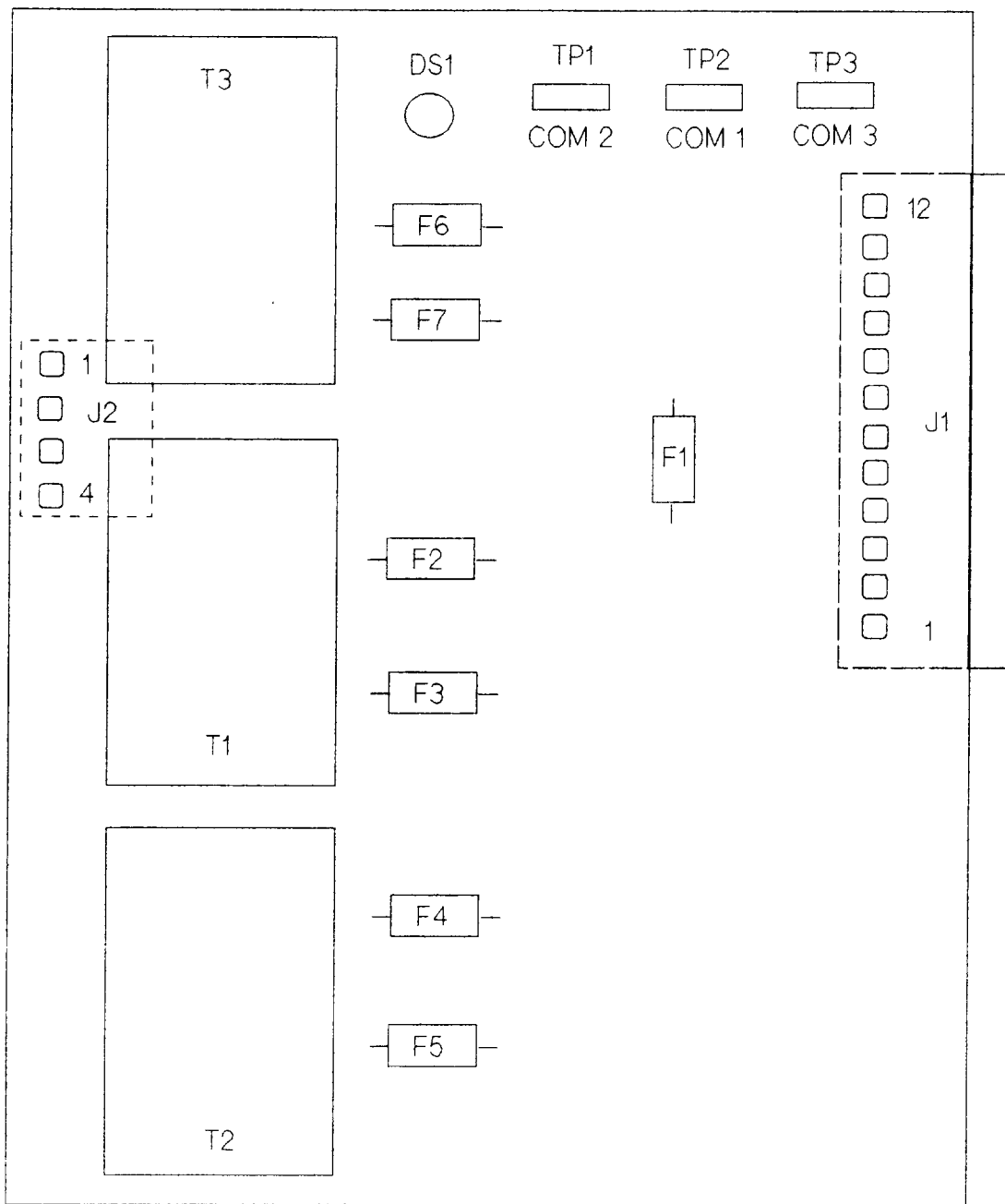

Figure 6-8. A10 Auxiliary Power Supply Assembly Schematic



NOTE: All fuses are 1 amp 125 V

Figure 6-9. A14 Bias Power Supply Board Parts Location

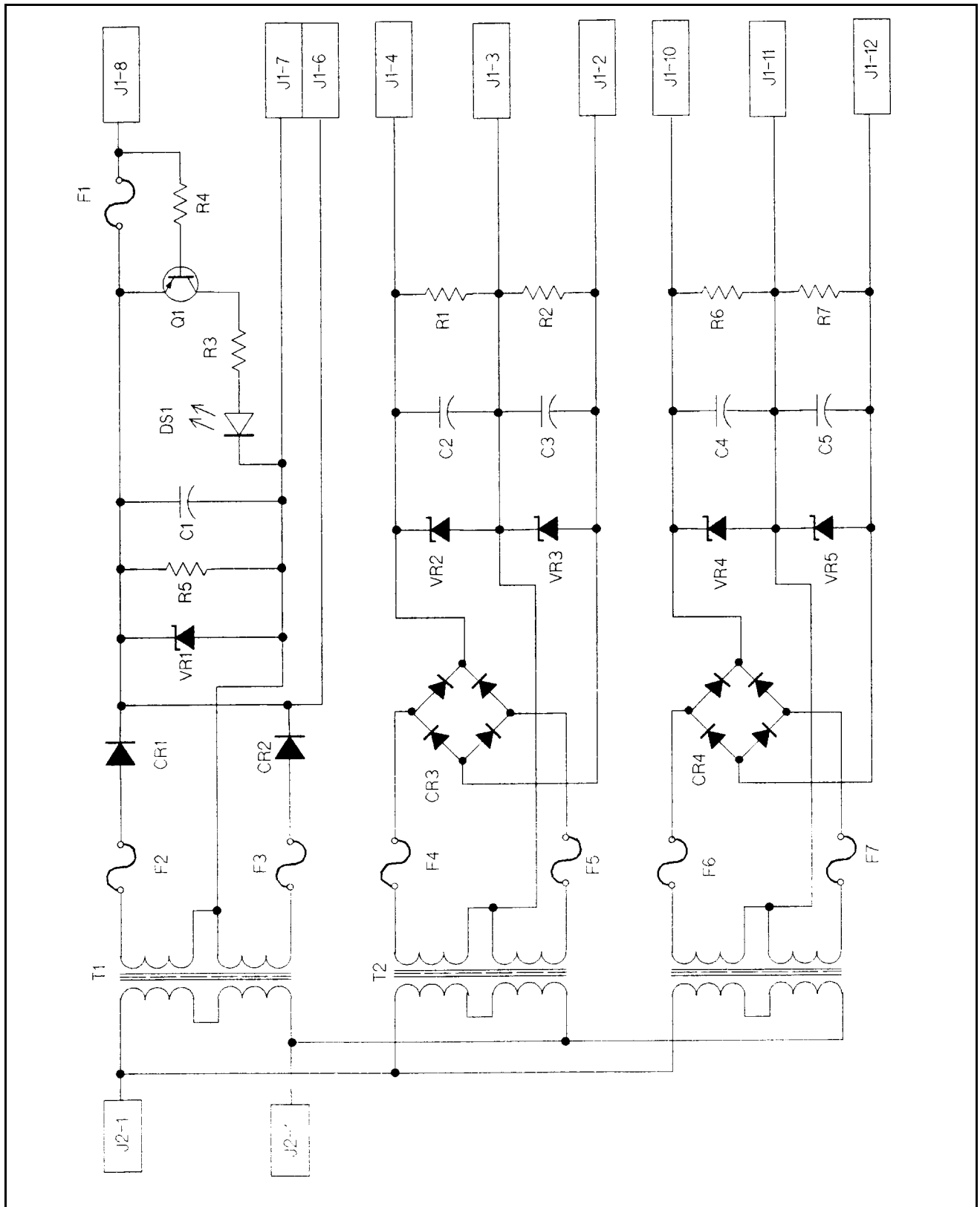

Figure 6-10. A14 Bias Power Supply Assembly Schematic

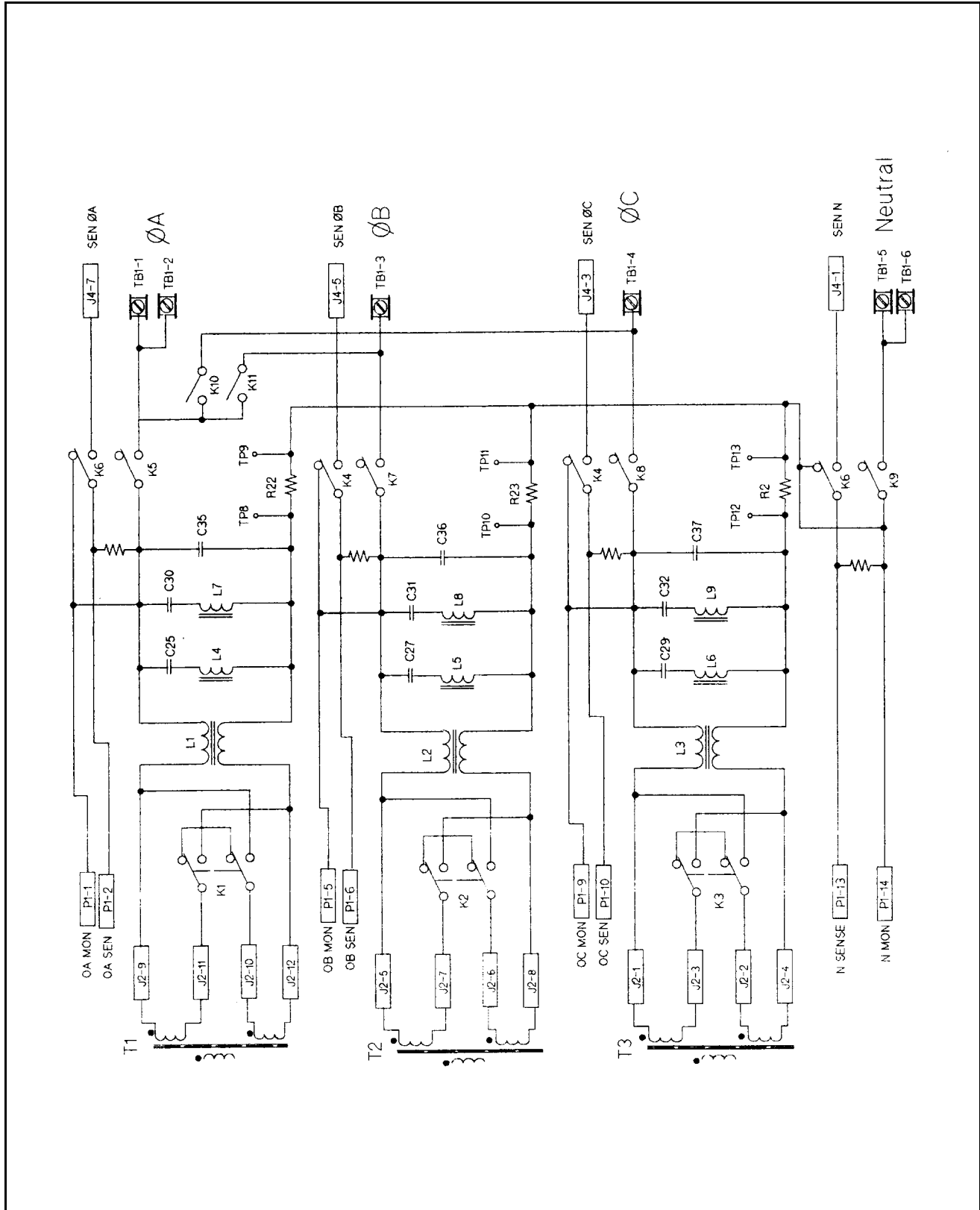

Figure 6-11. A5 Range/Output/Phase Relay Schematic

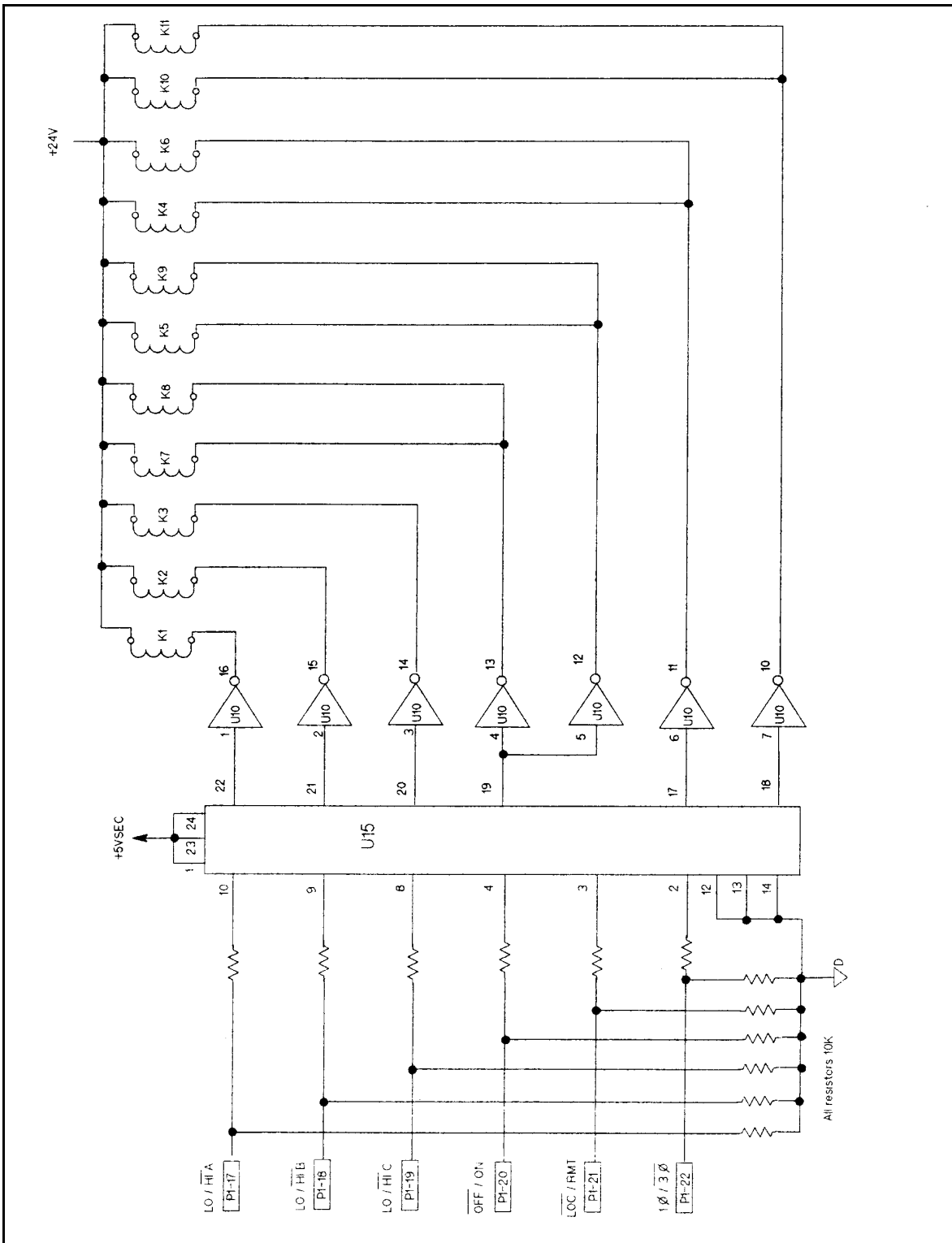
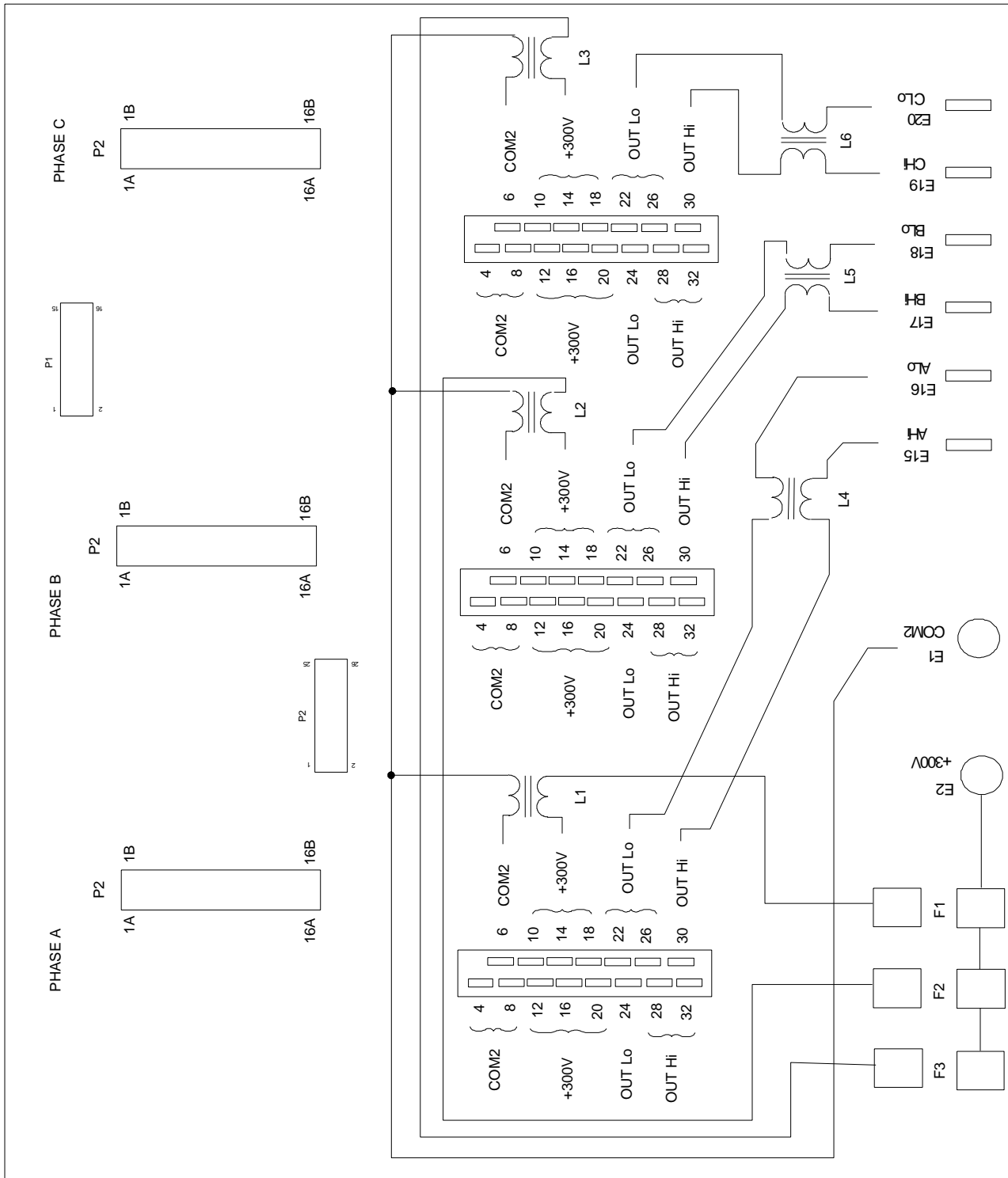

Figure 6-12. A5 Range/Output/Phase Relay Driver Schematic



COMMON MODE INDUCTORS L1, L2, L3, L4, L5 and L6
MOUNTED ON FAR SIDE OF A4 MOTHER ASSEMBLY

Figure 6-13. A4 Mother Board Parts Location

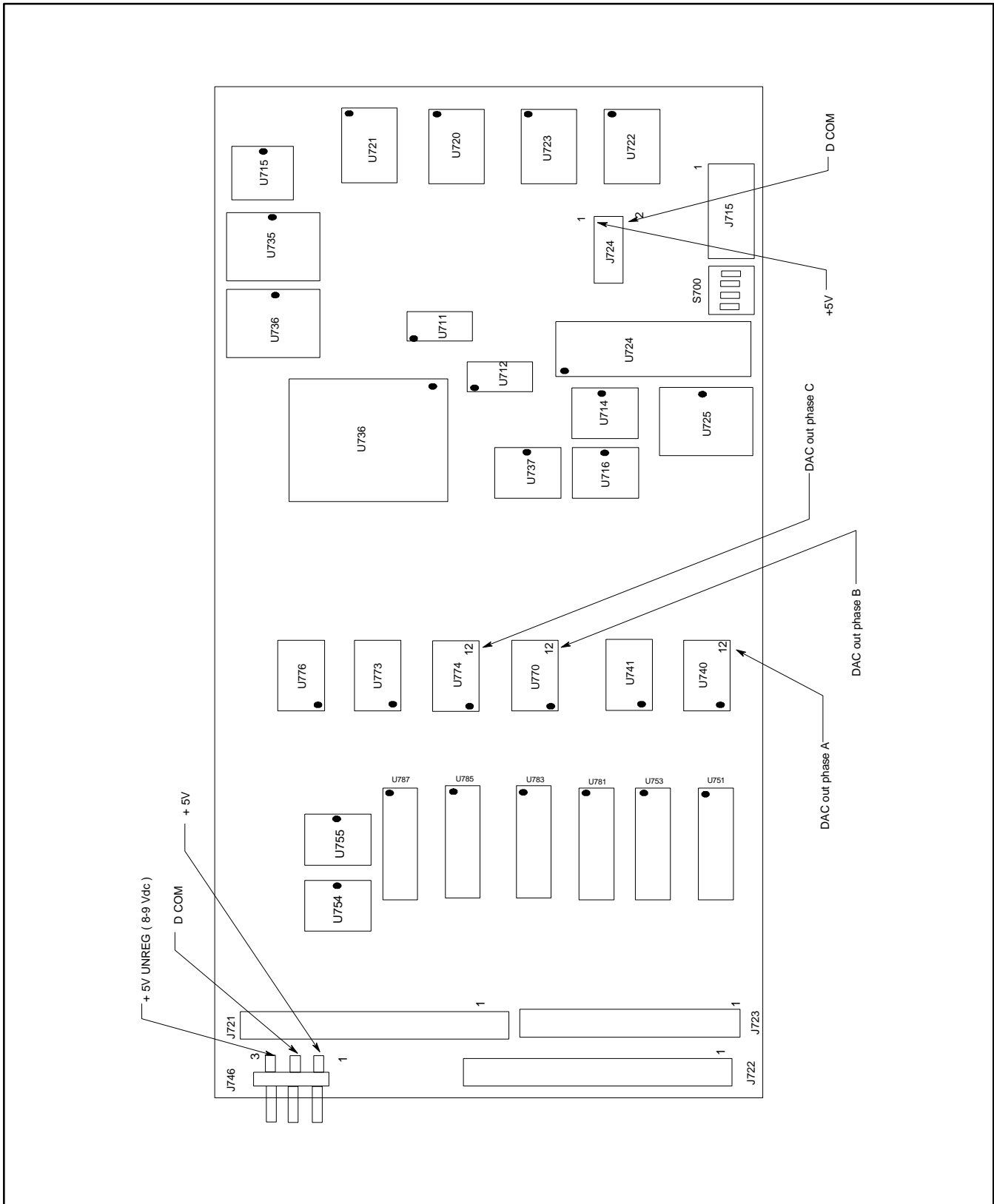

Figure 6-14. A8 DSP Board Parts Location

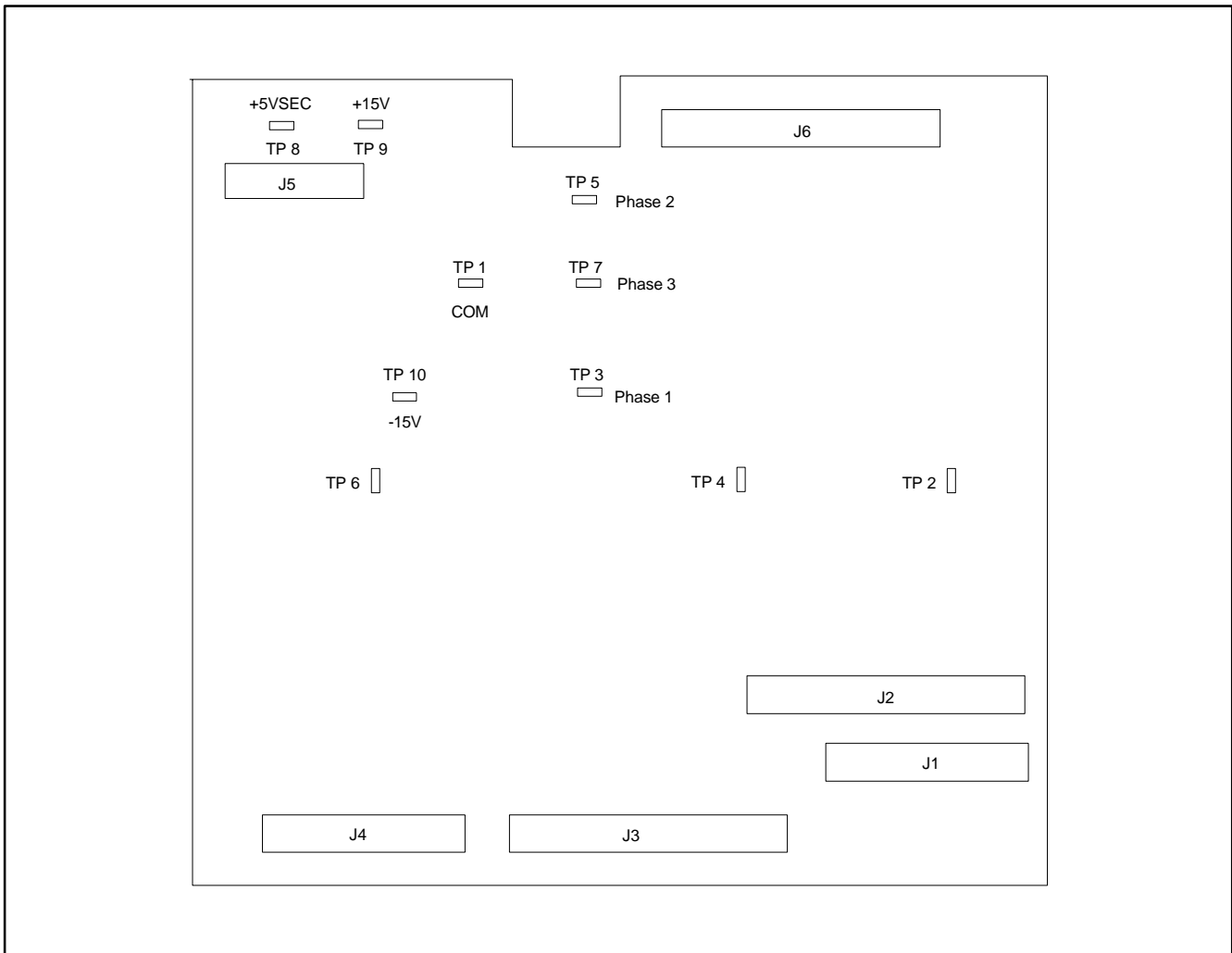

Figure 6-15 A6 Servo Board Test Point Location

Index

A

AC Power Source modules..... 31

C

calibration configuration switch..... 21
change sheets..... 8
clear password
 switch position..... 21
commands
 CAL ON command..... 20
 EEINIT command..... 20
conductive table mat..... 8
conductive wrist strap..... 8
configuration switch
 for calibration..... 21
current limiting resistors..... 32, 33
current-monitoring resistor..... 9

E

electrostatic discharge..... 8, 19
error code, over HP-IB..... 21
ESD..... 8, 19

F

fan speed control..... 33
fault isolation..... 21
firmware revisions..... 8, 20
Form, performance test record..... 13
fuses
 A10F1-F7 fuse..... 33
 A9F1-F4..... 32
 AC main fuses..... 23
 F2, F3, F4, F5..... 33
 subminiature fuses A10F2, A10F7..... 33

G

general description..... 31

H

hazardous voltages..... 7
hazards
 shock..... 19

Index (continued)

I

*IDN query.....	20
inhibit cal	
switch position.....	21
initializing the unit.....	20

L

localizing problems	19
---------------------------	----

M

manual backdating	8
manual changes sheet.....	8
manual revisions.....	8
measurement general techniques.....	9
microswitches	
internal.....	21
modules	
A10 auxiliary power supply	33
A11 front panel display assembly.....	33
A12 input filter assembly.....	33
A13 bridge capacitor filter assembly	33
A14 bias power supply.....	33
A1, A2, A3 switching amplifier modules	31
A4 mother board assembly.....	31
A5 relay range/sense assembly.....	32
A6 servo control assembly	32
A7 IEEE-488 HP-IB / RS-232 interface assembly	32
A8 digital signal processing assembly.....	32
A9 input power assembly.....	32, 33
interface assembly	32

N

non-volatile memory corruption.....	20
normal cal	
switch position.....	21

O

OUT-OF-RANGE error	20
--------------------------	----

P

performance test record form	13
performance test record sheets	14-16
performance tests.....	10
procedures	
troubleshooting.....	23
protective earth ground.....	8

Index (continued)

R

ram error	21
reinitializing unit.....	20
related documents.....	7
resistor	
current-monitoring	9
revisions	8
ROM replacement	20
ROM update	20
ROM versions.....	20

S

safety considerations.....	3, 7
safety warnings.....	7
serial number.....	4
serial number prefix.....	4
shock hazards	19

T

test equipment required	9, 19
tests	
cv load effect	11
cv source effect	11
frequency programming.....	10
harmonic distortion	12
readback accuracy.....	10
rms current accuracy.....	12
voltage programming.....	10
troubleshooting	
test equipment	19
troubleshooting hints	22
troubleshooting procedure.....	19
troubleshooting table	23
*TST? query.....	19

U

undervoltage / overvoltage detection circuits.....	32
updating ROM versions	20
using *IDN query	20

V

verification	9
--------------------	---

Manual Updates

The following updates have been made to this manual since the print revision indicated on the title page.

7/5/99

The Digital Voltmeter Characteristics on page 9 have been corrected.

The Output Balance Adjustments on page 22 have been updated.

Step 6 on page 23 has been corrected.

The note on the bottom of page 25 has been updated.

The fuses, rear panel, and rear panel label part numbers in table 5-1 have been updated (pp. 35-6)